



MONKEY RINGS

SURGICAL TECHNIQUE GUIDE

Circular External Fixation

Exclusively foot & ankle ²⁰
Paragon®



PRODUCT DESCRIPTION

The Monkey Rings™ External Fixation System allows for modular flexibility in circular external fixation constructs. Half Pin and Wire placement, as well as Construct type, will depend on the injury or condition being addressed. Ring size, use of Struts or Threaded Rods, and Half Pins or Wires is all left to surgeon discretion.

Acknowledgment:

Paragon 28® would like to thank Dr. Byron Hutchinson, DPM and Dr. Mark Easley, MD for their contribution to the surgical technique guide.

CONTENTS

Section 1	MONKEY RINGS™ CIRCULAR EXTERNAL FIXATION
	SYSTEM COMPONENTS AND INSTRUMENTATION 3-9
	FRAME BUILDING GUIDELINES.....10-13
Section 2	APPLICATION
	CIRCULAR EXTERNAL FIXATION..... 14-28
Section 3	INDICATIONS, CONTRAINDICATIONS, WARNINGS..... 29-30

SYSTEM COMPONENTS AND INSTRUMENTATION

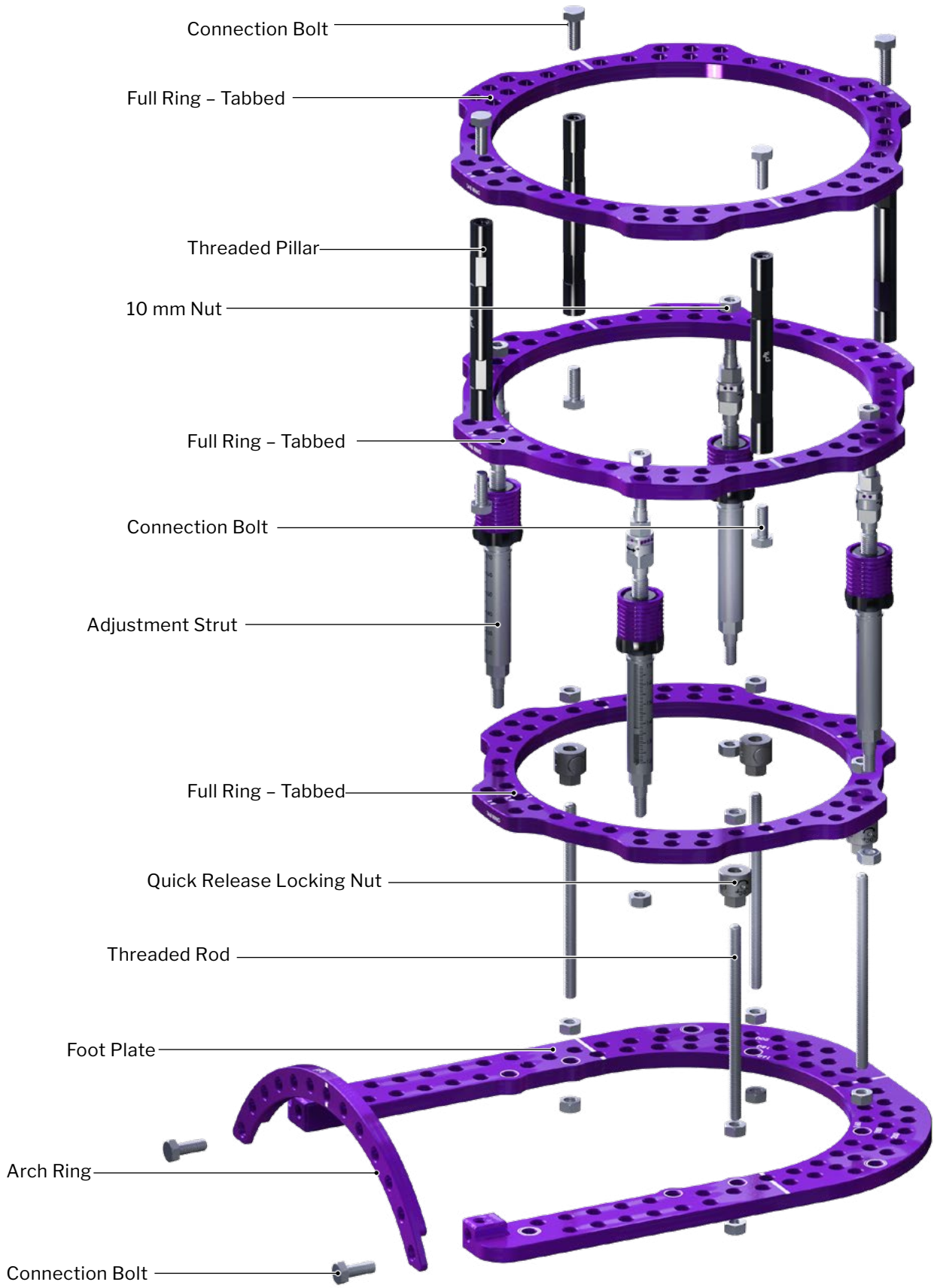

SYSTEM COMPONENTS AND INSTRUMENTATION

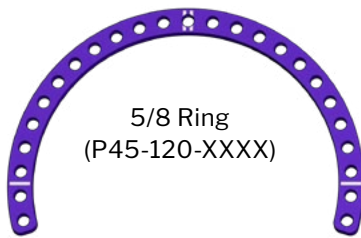
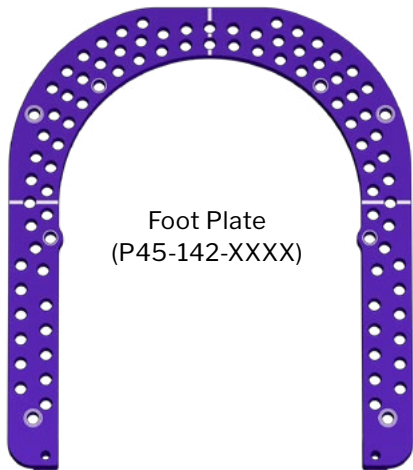
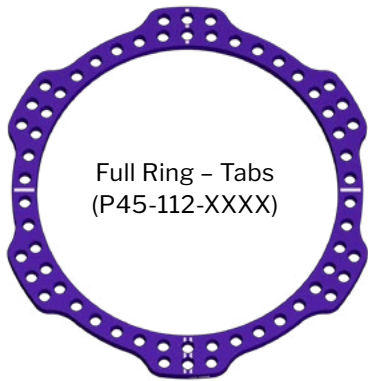
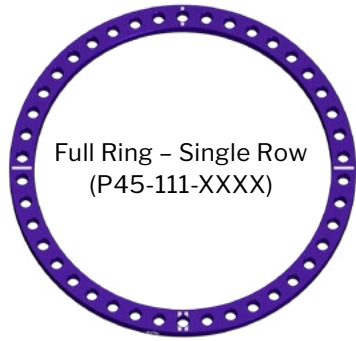

Ring Sizers
(P45-999-1000)

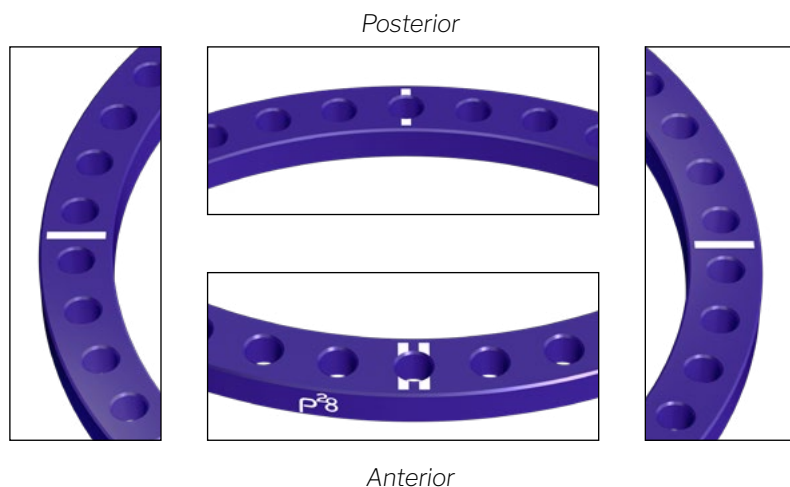



Double marking is to denote the anterior orientation of the Ring, while the other three single markings denote the medial, lateral, and posterior orientation.



SYSTEM COMPONENTS AND INSTRUMENTATION

The size charts below depict the compatibility of the system's Ring/Foot Plates and specifies which Plates come standard in the caddy. All other Plate sizes are available by request.

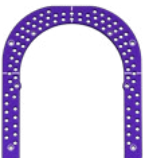
Key:

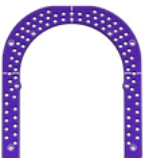

- = Available in caddy
- = Sizes compatible
- = Available for order
- = Sizes non-compatible



		 Foot Plate					
		120 mm	140 mm	160 mm	180 mm	200 mm	220 mm
 Full Ring	80 mm						
	100 mm						
	120 mm						
	140 mm						
	160 mm						
	180 mm						
	200 mm						
	220 mm						

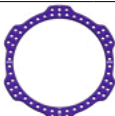

		 Foot Plate					
		120 mm	140 mm	160 mm	180 mm	200 mm	220 mm
 Tabbed Ring	80 mm						
	100 mm						
	120 mm						
	140 mm						
	160 mm						
	180 mm						
	200 mm						
	220 mm						

SYSTEM COMPONENTS AND INSTRUMENTATION

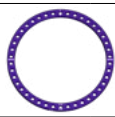
Key: = Available in caddy = Sizes compatible
 = Available for order = Sizes non-compatible

		 Tabbed Ring							
		80 mm	100 mm	120 mm	140 mm	160 mm	180 mm	200 mm	220 mm
 Tabbed Ring	80 mm								
	100 mm								
	120 mm								
	140 mm								
	160 mm								
	180 mm								
	200 mm								
	220 mm								

		 Full Ring							
		80 mm	100 mm	120 mm	140 mm	160 mm	180 mm	200 mm	220 mm
 Full Ring	80 mm								
	100 mm								
	120 mm								
	140 mm								
	160 mm								
	180 mm								
	200 mm								
	220 mm								

		 Tabbed Ring							
		80 mm	100 mm	120 mm	140 mm	160 mm	180 mm	200 mm	220 mm
 Full Ring	80 mm								
	100 mm								
	120 mm								
	140 mm								
	160 mm								
	180 mm								
	200 mm								
	220 mm								

SYSTEM COMPONENTS AND INSTRUMENTATION

Adjustment Strut (P45-224-XXXX)

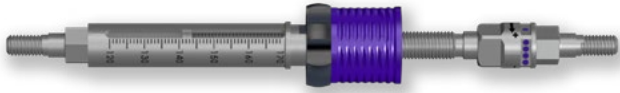

Strut Lengths Available		
Small 100 mm-129 mm	Medium 120 mm-170 mm	Large 160 mm-250 mm

Threaded Rod (P45-310-XXXX)

Allow for the adjustments in the length between the Ring or Foot Plates.



Rod Lengths Available				
30 mm	60 mm	80 mm	100 mm	120 mm
150 mm	200 mm	250 mm	300 mm	

Threaded Pillar (P45-330-XXXX)

Threaded Pillars are available in static lengths.



Pillar Lengths Available			
30 mm	50 mm	75 mm	100 mm
150 mm	200 mm	250 mm	300 mm

Universal Pin Clamp
(P45-970-2000)



Wire Fixation Bolt
(P45-913-2001)

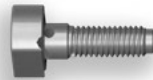

Connection Bolt
(P45-914-XXXX)

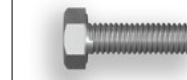

Connection Bolt Lengths Available		
8 mm	16 mm	20 mm

Quick Release Locking Nut
(P45-941-0002)



Quick Release Locking Nut Wrench
(P45-517-0001)



M6 Connecting Nut, 10 mm Hex
(P45-940-0001)



Locking Hinge
(P45-912-1000)



Locking Universal Joint
(P45-912-2000)



M6 Long Extension Nut, Compression/Distract, 10mm Hex
(P45-941-0001)



Convex Spherical Washer
(P45-944-0001)



Concave Spherical Washer
(P45-944-0002)



Washer
(P45-943-XXXX)



Washer Sizes Available		
1 mm	2 mm	4 mm

Female Extension Posts without threaded attachment (Female)
(P45-920-XXXX)



Male Extension Posts with Threaded Attachment (Male)
(P45-921-XXXX)



Male/Female Extension Post Holes Available		
2 Hole	3 Hole	4 Hole

Rancho Cubes
(P45-925-XXXX)



Rancho Cube Holes Available			
2 Hole	3 Hole	4 Hole	5 Hole

Rancho Cube Centering Collars
(P45-925-XXXX)



Centering Collar Diameters Available		
4.0 mm	5.0 mm	6.0 mm



Offset Slotted Ring Adapter (Short)
(P45-935-XXXX)



Offset Slotted Ring Adapter (Long)
(P45-935-XXXX)



SYSTEM COMPONENTS AND INSTRUMENTATION

	Drill Tip	Diameters Available	Overall Length	Thread Length	Drill
Half Pin Size	Self-Drilling (P45-191-XXXX) 	Ø4.0	95 mm	35 mm	Ø2.4
		Ø5.0	95 mm	35 mm	Ø3.4
		Ø5.0	160 mm	45 mm	Ø3.4
		Ø6.0	160 mm	35 mm	Ø4.4
		Ø6.0	160 mm	45 mm	Ø4.4
	Self-Drilling (Hydroxyapatite Coating) (P45-199-XXXX-S) 	Ø4.0	120 mm	35 mm	Ø2.4
		Ø5.0	180 mm	50 mm	Ø3.4
		Ø6.0	180 mm	50 mm	Ø4.4
	Blunt Tipped (P45-196-XXXX) 	Ø4.0	95 mm	35 mm	Ø2.4
		Ø5.0	160 mm	35 mm	Ø3.4
		Ø5.0	160 mm	45 mm	Ø3.4
		Ø6.0	160 mm	35 mm	Ø4.4
		Ø6.0	160 mm	45 mm	Ø4.4



NOTE: Pre-drilling is always recommended regardless of Half Pin type.

SYSTEM COMPONENTS AND INSTRUMENTATION

Smooth Wire (P45-194-1840)
1.8 x 400 mm



Reduction Wire (P45-195-0007)
1.8 x 400 mm



10 mm Wrench
(P47-950-0001)



5 mm Hex Universal Joint Wrench
(P45-515-0001)



*Fits Locking Universal Joint and
Locking Hinge*



T-Handle Driver
(P47-940-0001)

*Fits AO and 10 mm
hex components*

10 mm Angled Socket Wrench
(P45-513-0001)



10 mm Slotted Angled Socket Wrench
(P45-513-0002)



10 mm Tang Angled Socket Wrench
(P45-513-0003)



Wire Tensioner
(P45-540-0000)

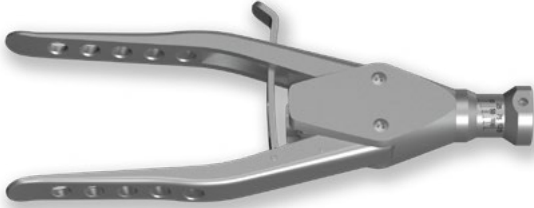

Snub Nose
Attachment
(P45-540-0001)



Long Nose
Attachment
(P45-540-0002)



Ø6.0 Split Tissue Protector Sleeve
(P45-580-1000)

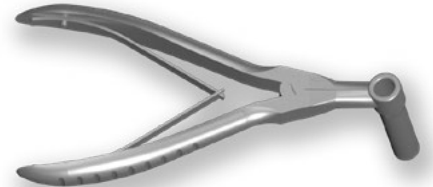

Wire Cutter
(P99-150-0121)



Pin Cutter
(P45-520-2000)

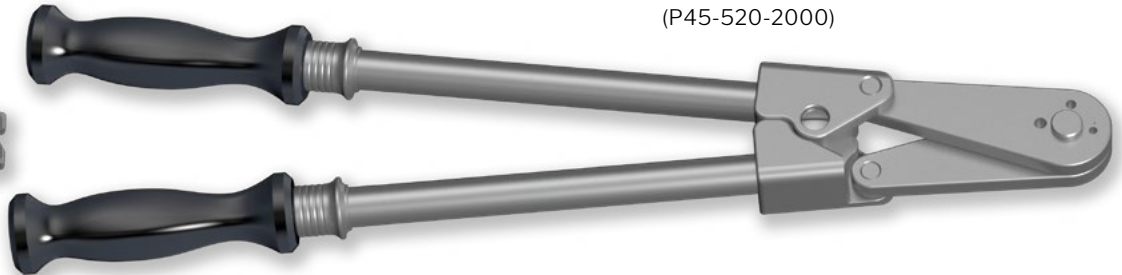

Pin and Wire Site Protective
Sponge Fasteners (pack of 12)
(P45-610-1000)



Infection Shielding Pin and Wire
Site Protective Sponges,
Sterile Packed (pouch of 30)
(P45-600-1000-S)



Foot Rocker
(P45-170-1000)



Strut Locking Clip
(pouch of 10)
(P44-PKG-4001)



Wire Clamp Caps
(pouch of 16)
(P45-198-1000)



Protective Cap (pouch of 10)
(P45-198-XXXX)

	Diameters Available		
	4.0 mm	5.0 mm	6.0 mm

FRAME BUILDING GUIDELINES

Pre-assemble the proximal tibial ring block by connecting two Full Rings. Connect using either Threaded Pillars and 16 mm Connecting Bolts or Threaded Rods and M6 Connecting Nuts affixed to both sides of each ring. Tabbed or Single Row Full Rings may be used per surgeon preference.



NOTE: Ring Sizers are provided to determine the correct ring size pre-operatively. When measuring utilizing the Ring Sizer, ensure a minimum distance of 2 cm between the Ring Sizer and the skin at all points.



OPTIONAL:

Alternatively, the proximal tibial ring block may also be built using Threaded Rods and 10 mm M6 Connecting Nuts on either side of the Full Rings.



A 5/8 Ring may be used as an alternative to the most proximal Full Ring to allow for more range of motion at the knee and to prevent the posterior side of the leg from swelling into the fixator.

Demonstrated here, the Locking Universal Joints may also be used if off axis positioning of the struts is required. Ensure that the Quick Adjust Struts read-outs are visible and the two Universal Joint Locking Nuts are secured using the 5 mm Hex Universal Joint Wrench.

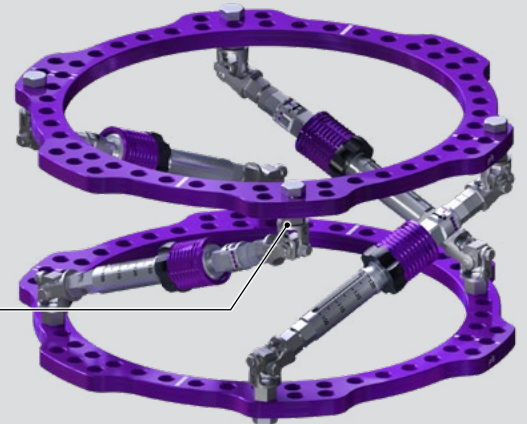
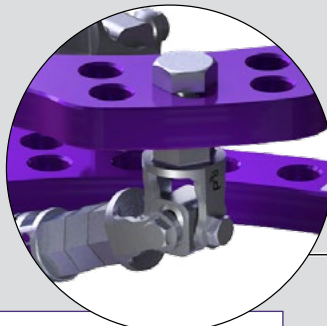

NOTE: The use of a 10 mm M6 Connecting Nut is required to maintain position of the Universal Joint when used with the Quick Adjust Strut.

FRAME BUILDING GUIDELINES

Build distal Foot Plate assembly construct according to surgeon preference. Shown below is a Full Tabbed Ring attached to a Foot Plate using Threaded Rods. This can also be referred to as the distal ring block.



The Foot Plate has double rings to note the placement of the Foot Rocker at a later time.

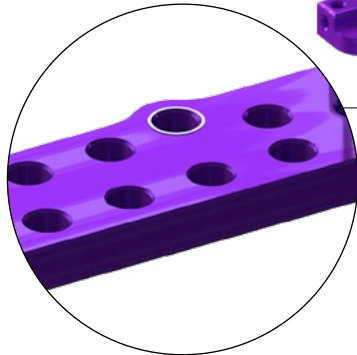

The two protruding holes of the Foot Plate allow for greater than 180° of functionality to increase the frame stability and are the preferred mounting site for the Threaded Rods.

Prior to connecting the proximal and distal ring blocks, ensure the Threaded Rods are aligned with the markings on the Tabbed Full Rings. The double markings on the Rings should be oriented anterior to posterior in relation to the tibia.

OPTIONAL:

For a constrained construct, a 5/8 Ring may also be used for placement of Wires into the talus and independent compression of the tibiotalar joint. See safe zone on page 22 for fixation placement guidelines in the talus.

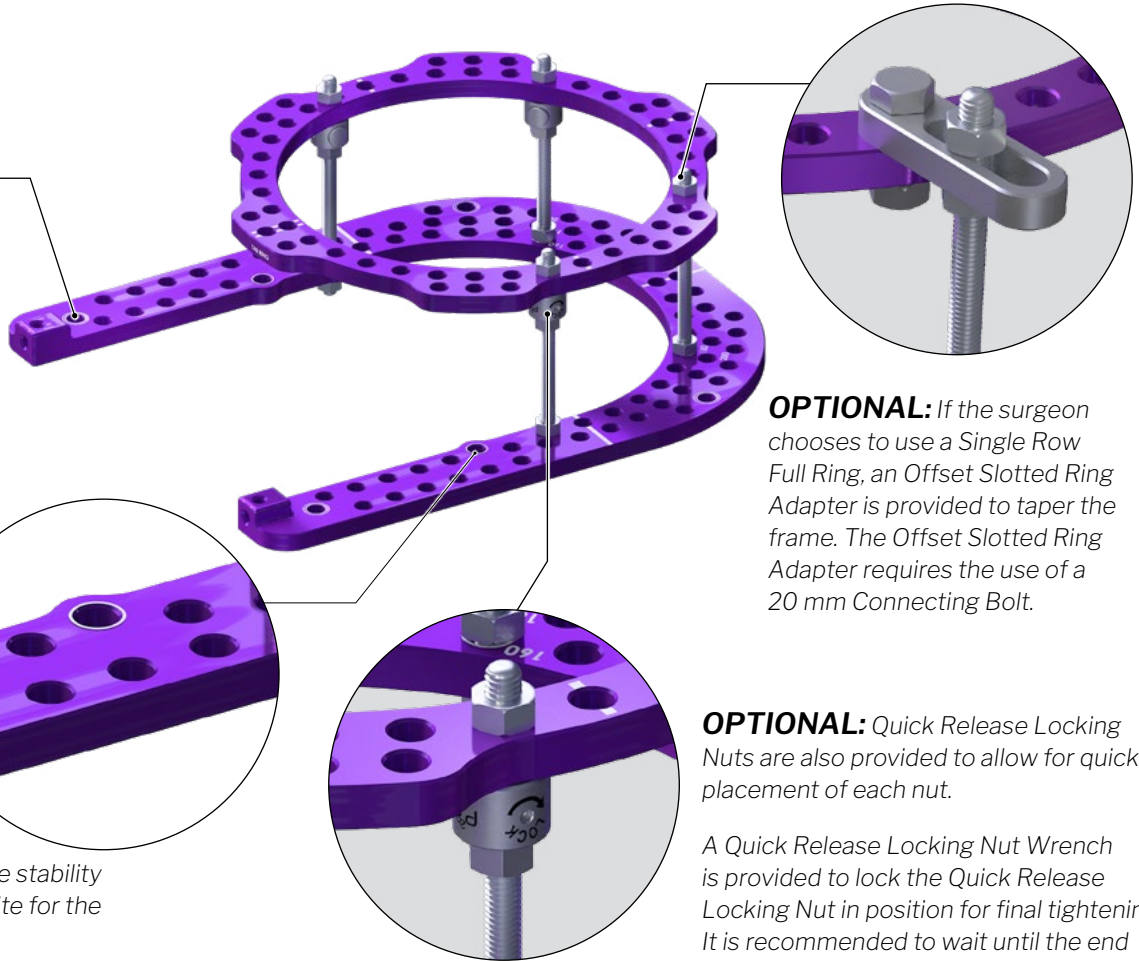

OPTIONAL: If the surgeon chooses to use a Single Row Full Ring, an Offset Slotted Ring Adapter is provided to taper the frame. The Offset Slotted Ring Adapter requires the use of a 20 mm Connecting Bolt.

OPTIONAL: Quick Release Locking Nuts are also provided to allow for quicker placement of each nut.

A Quick Release Locking Nut Wrench is provided to lock the Quick Release Locking Nut in position for final tightening. It is recommended to wait until the end of the case to perform final locking of the Quick Release Locking Nut.

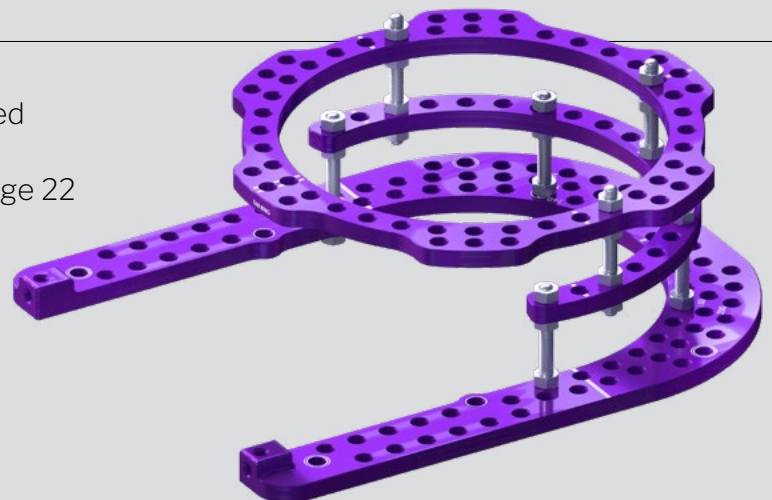

FRAME BUILDING GUIDELINES

Connect the distal ring block and proximal tibial ring block using either 4 Threaded Rods or Quick Adjust Struts to allow for length adjustment of the fixator intra-operatively.

There are both a gross and fine length adjustment method to the Quick Adjust Struts.

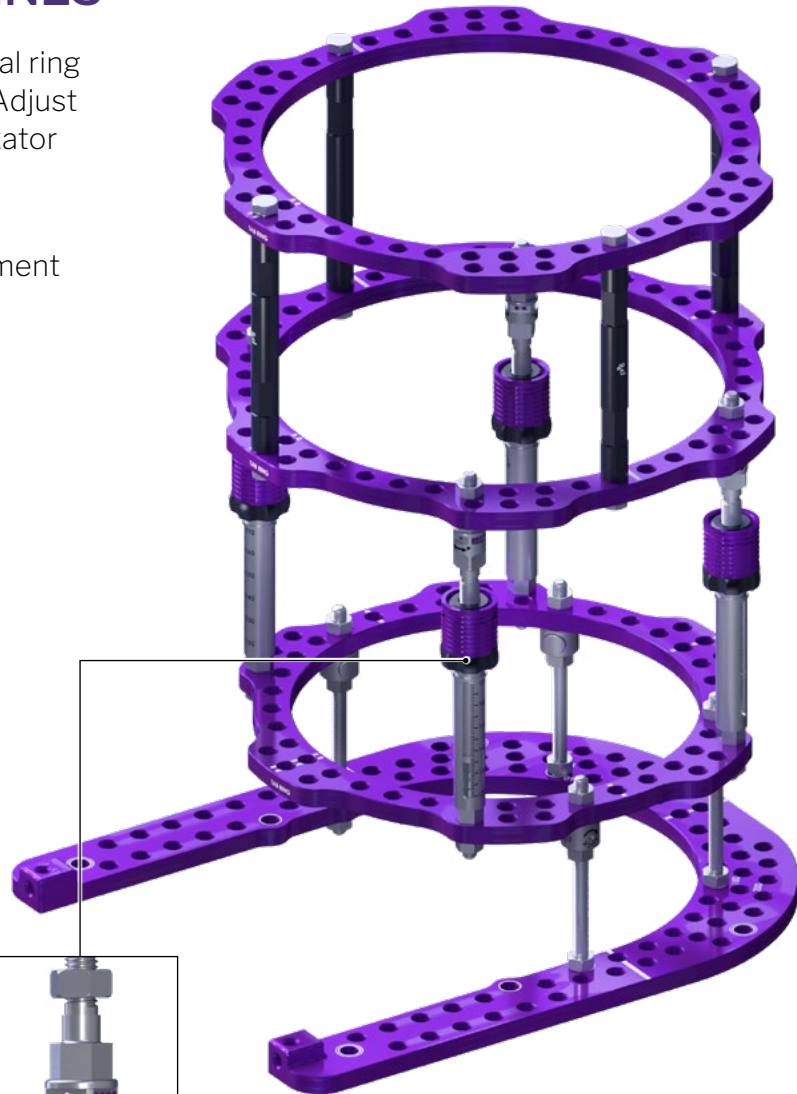

For micrometric gradual adjustment of the strut, turn square nut portion of the strut containing dice toward the + sign to lengthen and toward - sign to shorten. Each 1/4 turn or increase in dice signifies .25 mm of gradual lengthening or shortening. Gross adjustment strut must be locked in place to perform micrometric adjustment.



For rapid adjustments, make sure the black locking nut is disengaged by loosening completely and turning to the bottom. Pull the purple knob straight down to unlock and adjust strut to the desired length. Once desired length is achieved, pull the purple knob straight up to remain at the desired length. Twist black locking nut clockwise to the top to lock in place.

Quick Adjustment Strut

FRAME BUILDING GUIDELINES

An Arch Ring is recommended to be connected to the Foot Plate using 16 mm Connecting Bolts in order to prevent deformation of the Foot Plate construct during Wire tensioning.

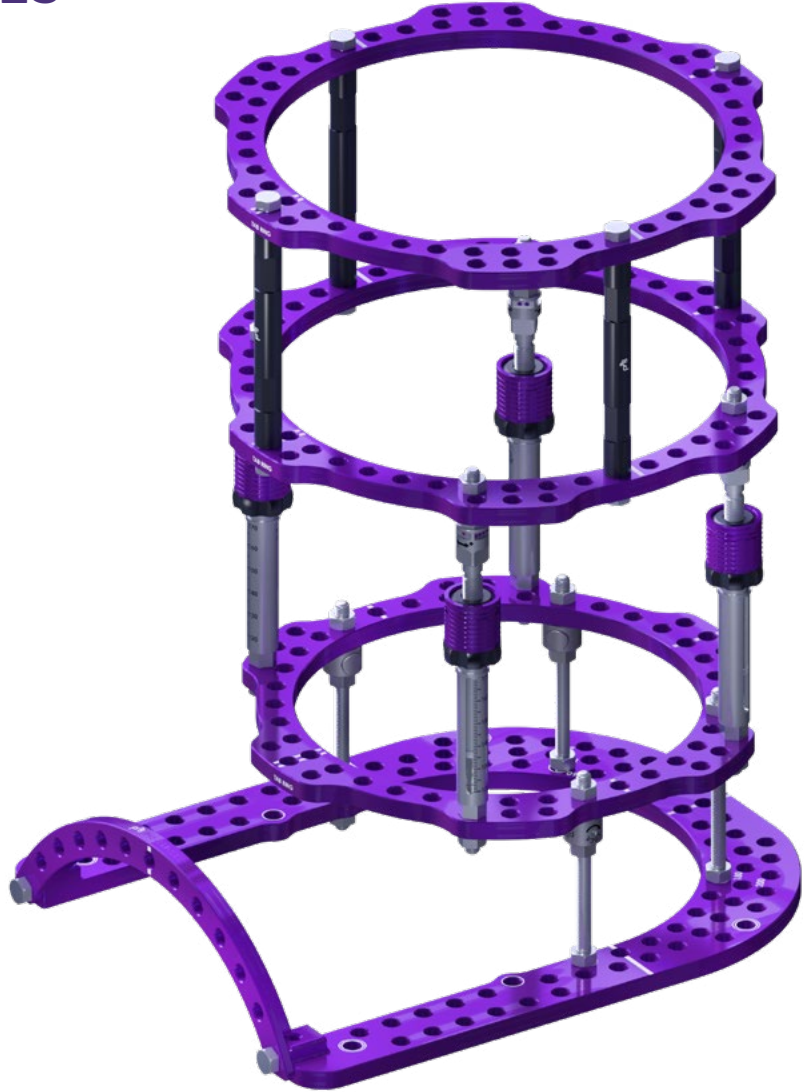

OPTIONAL:

Alternative constructs for Foot Plate closure may be used, including Extension Posts with Threaded Rods or a horizontal Half/Arch Ring for support.

Threaded Rod with Extension Post

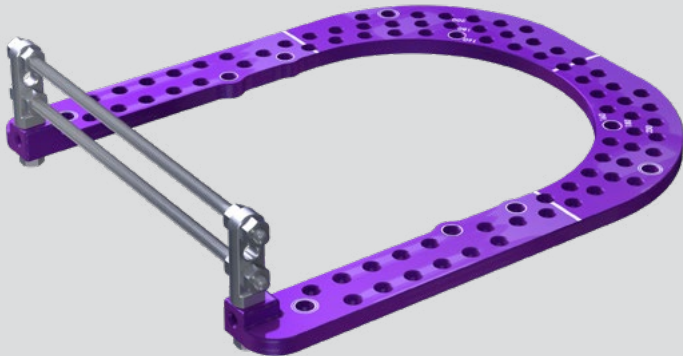

Horizontal Half Ring

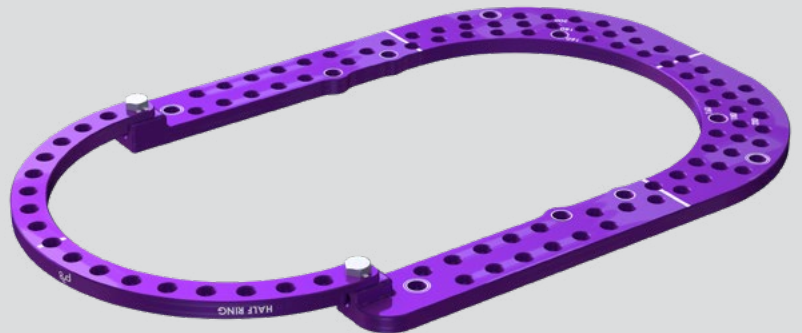

CIRCULAR EXTERNAL FIXATION APPLICATION

Position the patient's ankle joint at a 90° neutral position and align the Foot Plate with the plantar aspect of the foot. Ensure there is a 2 cm minimum distance from the fixator and any soft tissue on the patient.

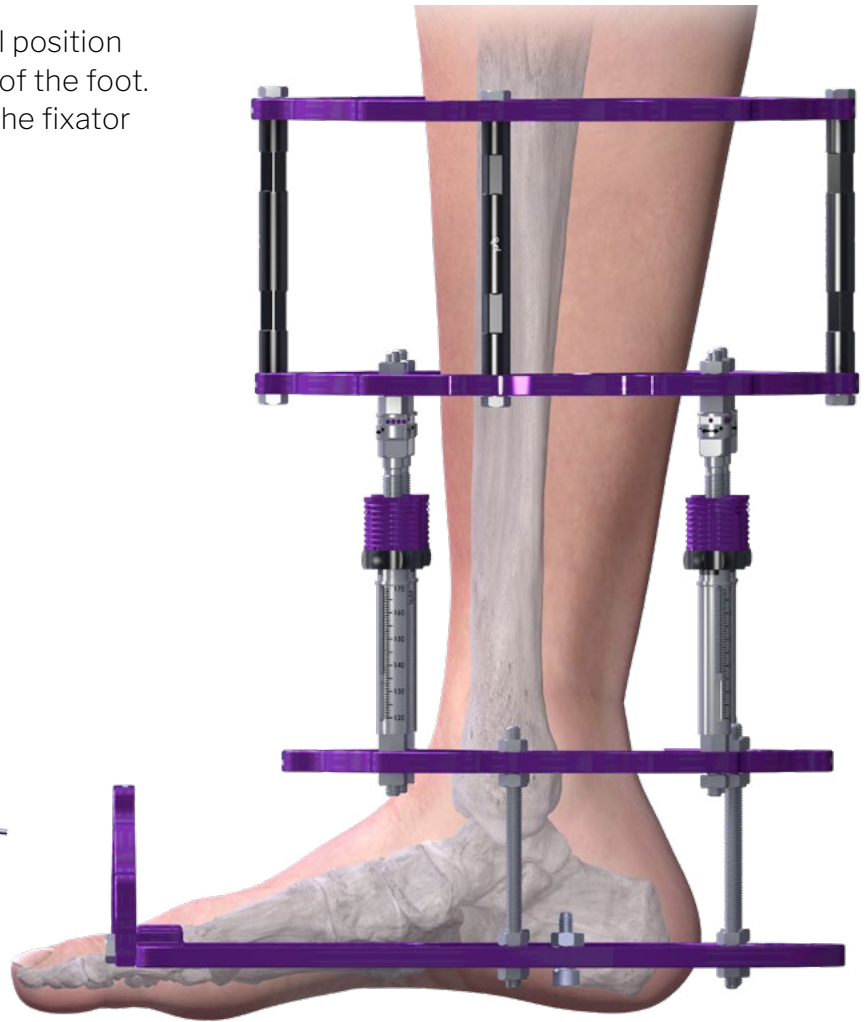

After sizing the frame on the patient, move the frame slightly proximal, away from the calcaneus, place a 1.8 mm Smooth Wire through the calcaneus from medial to lateral in the posterior calcaneal tuberosity. Slide the Foot Plate down to the reference Wire and connect the Smooth Wire to the Foot Plate using a Wire Fixation Bolt and M6 Connecting Nuts. Tighten, but do not tension the Smooth Wire and confirm position of the foot is correct.

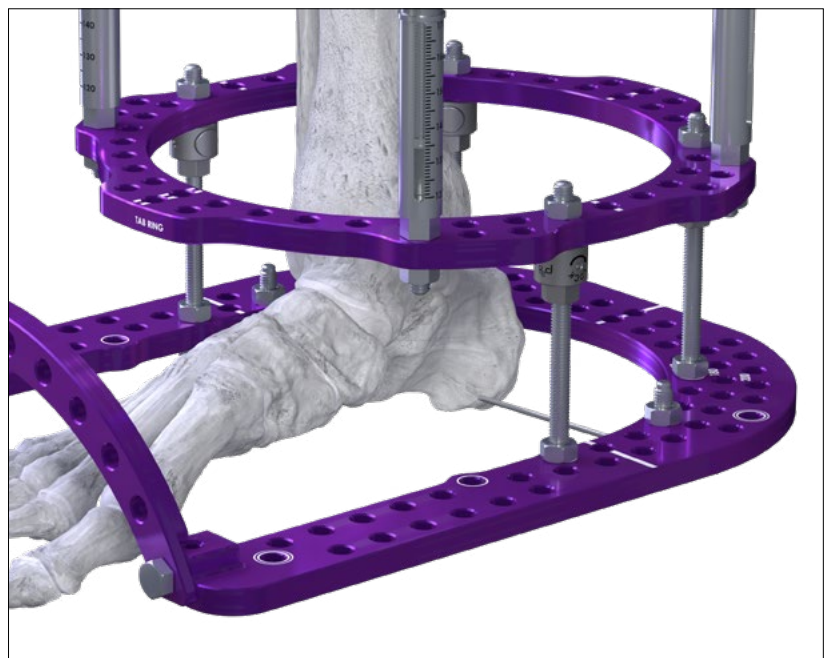

NOTE: For Charcot foot deformity, place the foot minimally below Foot Plate with Foot Rockers to load the frame. For limb lengthening, place foot further below Foot Plate so the patient is loading the bone and not the frame.

CIRCULAR EXTERNAL FIXATION APPLICATION

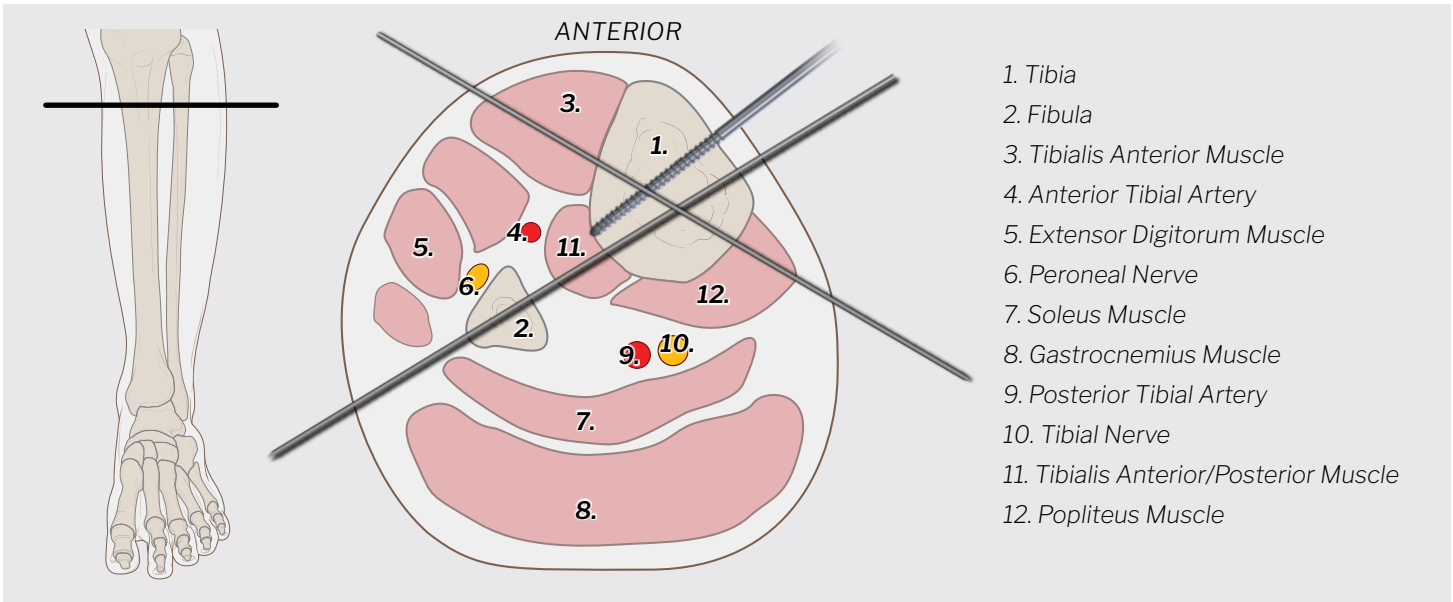

Care should be taken to avoid all major landmarks depicted above.

Position the proximal portion of the tibia either center or slightly anterior, relative to the proximal tibial ring block. Place a Smooth 1.8 mm Wire bi-cortically lateral to medial, while keeping on same plane and level as the fixator. Ensure the frame is orthogonal and that there is at least 2 cm of clearance from the frame to the soft tissue at all points. Once the desired position is obtained, affix the Wire to the frame using Wire Fixation Bolts and 10 mm M6 Connecting Nuts. Tighten, but do not tension the Wire. Smooth or Reduction Wires may be used per surgeon preference.

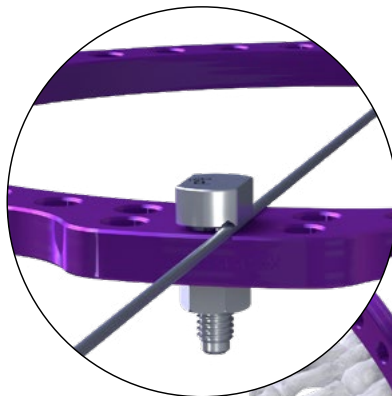
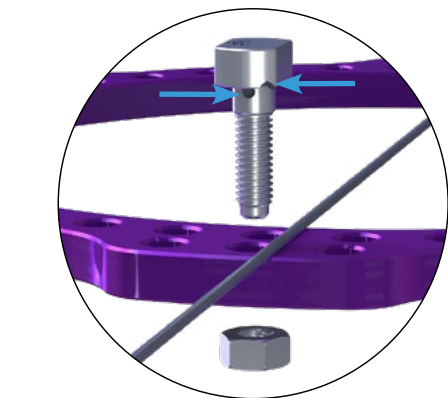
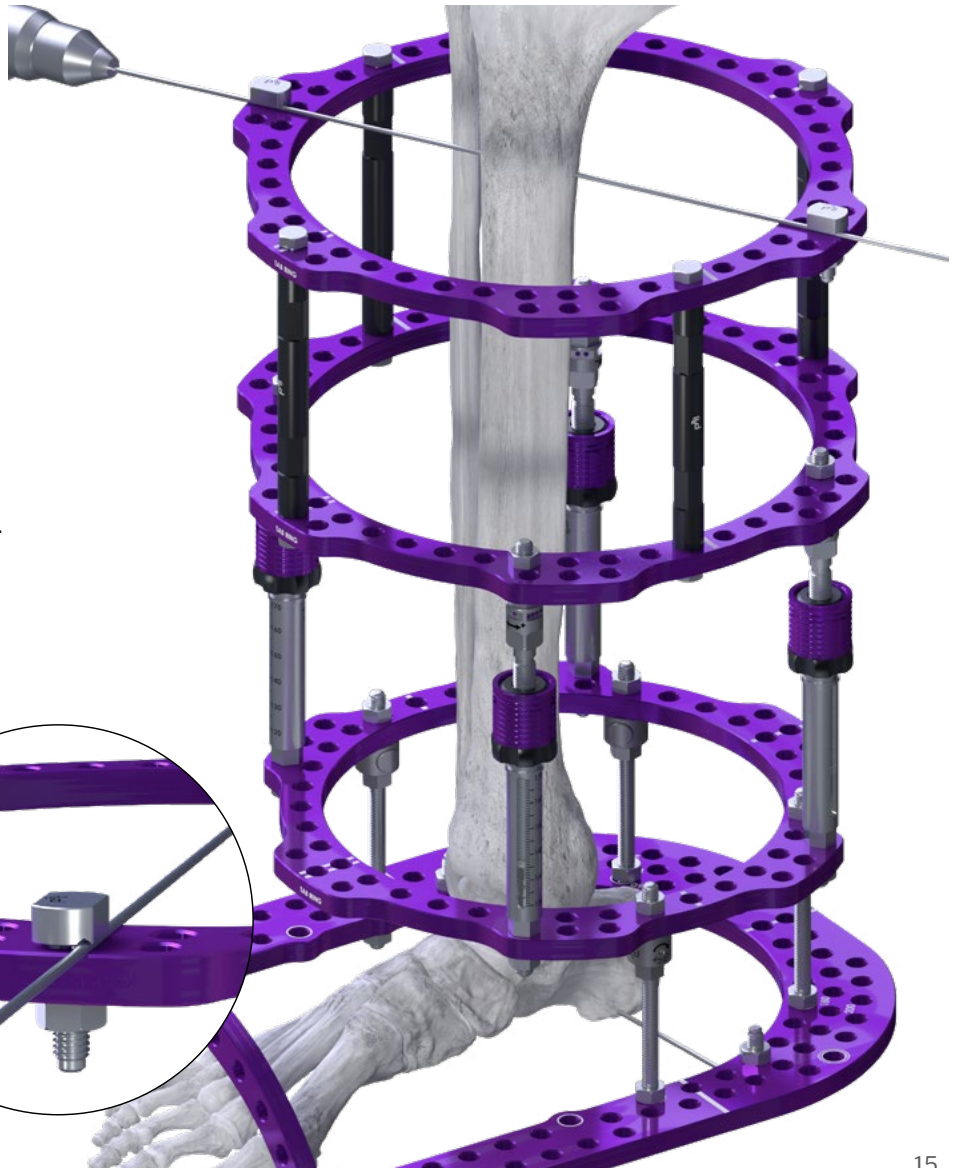

The Wire may be placed either through the center hole or the offset hole of the Wire Fixation Bolt.

CIRCULAR EXTERNAL FIXATION APPLICATION

Attach either a 3, 4, or 5-Hole Post or Rancho Cube to the most proximal Full Ring, to attach either a 4, 5, or 6 mm Half Pin.

Drilling is required to place a Blunt Half Pin and recommended for placement of a Self-Drilling Half Pin for optimal performance and bone purchase.

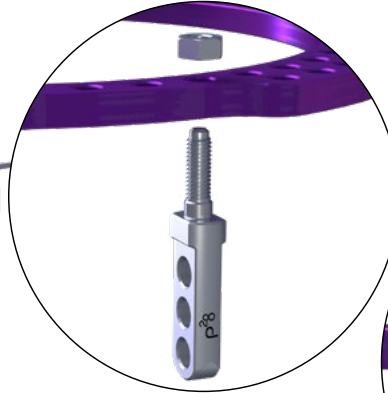

3-Hole Post Assembly



Half Pin Diameter	Drill Diameter
Ø4.0 mm	2.4 mm
Ø5.0 mm	3.4 mm
Ø6.0 mm	4.4 mm

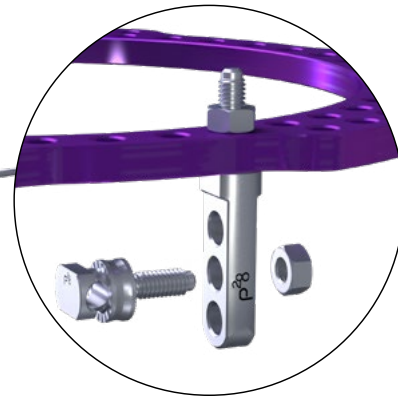

Secure the Half Pin to the Post using the Universal Pin Clamp and a 10 mm Nut using the provided 10 mm Wrench.

Location	Tension (kg)
Tibia	125 kg
Midfoot/Calcaneus	90-100 kg
Forefoot	50-70 kg



NOTE: If Wire is placed on a Post, do not tension past 75 kg. If Wire is positioned on an open 5/8 Ring, do not tension past 90 kg.

CIRCULAR EXTERNAL FIXATION APPLICATION

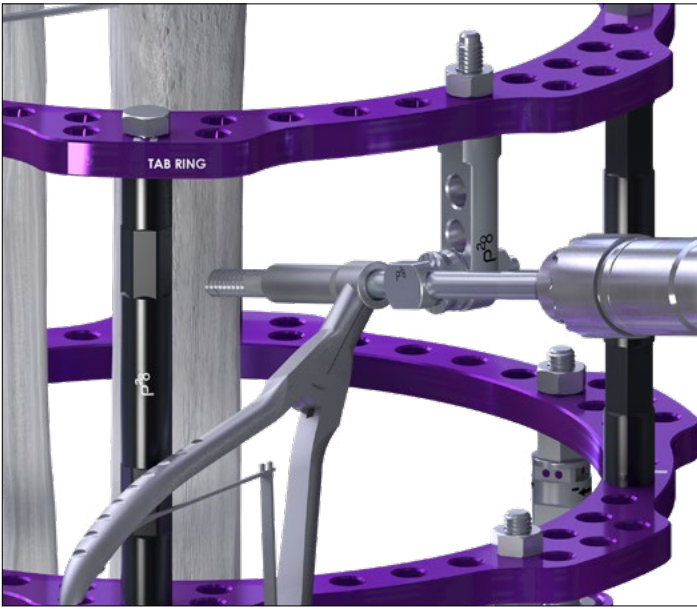

Drill using the appropriate sized Half Pin Drill. An optional $\varnothing 6.0$ Split Tissue Protector Sleeve is provided for the $\varnothing 6.0$ Half Pin.

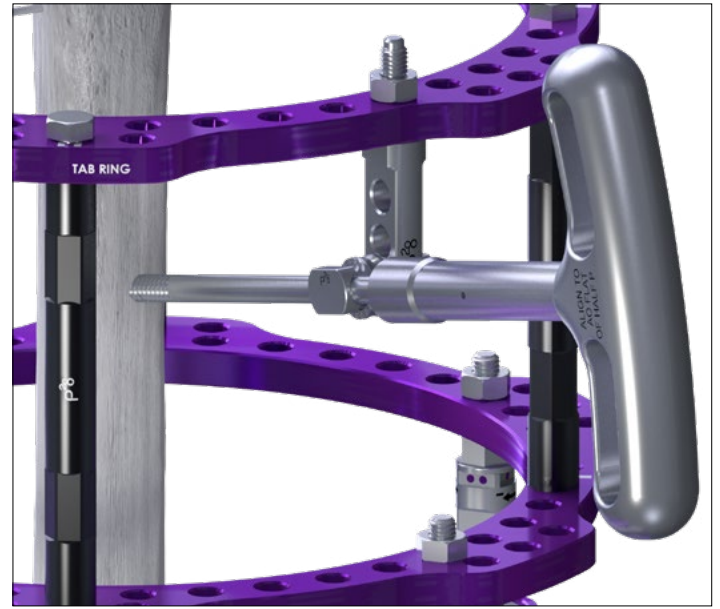

The Half Pin should be placed bi-cortically manually with the T-handle to avoid driving the Half Pin too far past the second cortex.

Once the Proximal Half Pin is placed, the Wire may be tensioned. Fully secure one end of the Wire and tension from the opposite end of the Wire until 125 kg of tension is reached.



NOTE: Check for bicortical placement of the Half Pin under fluoroscopy prior to cutting the Half Pin.

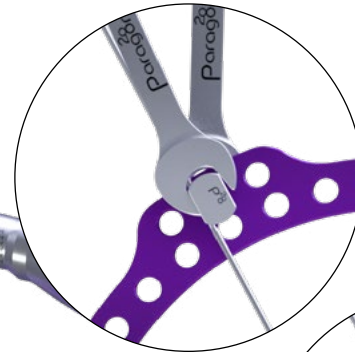
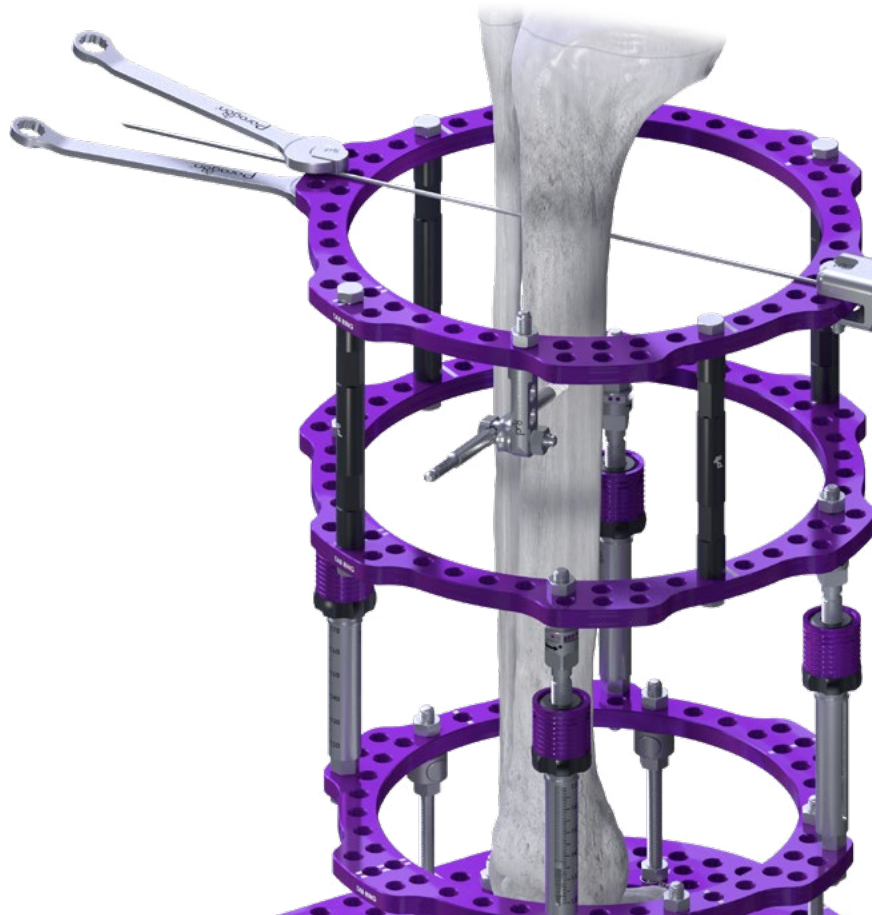

Wrench tighten

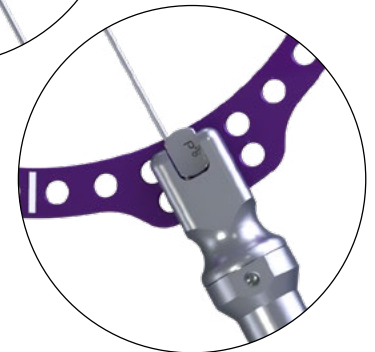

Wire Tensioner



NOTE: Both a Snub Nose and Long Nose attachment are offered per surgeon preference.

CIRCULAR EXTERNAL FIXATION APPLICATION

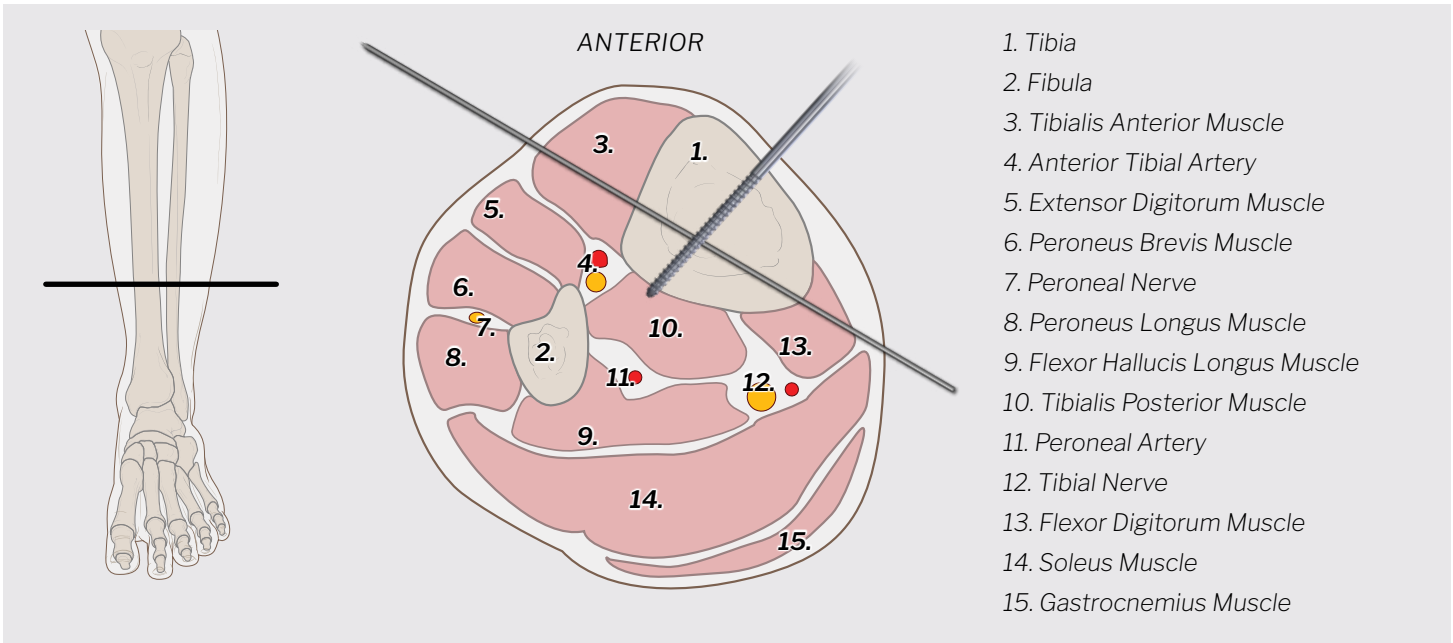

Care should be taken to avoid all major landmarks depicted above.

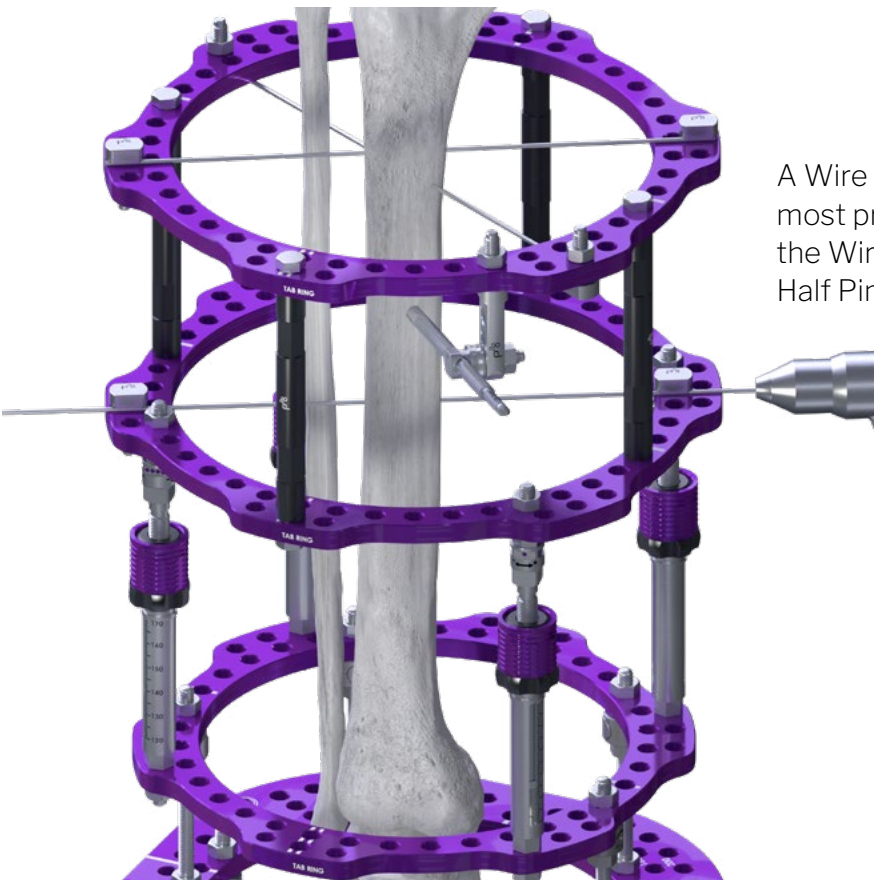

A Wire should be placed through the tibia at the second most proximal Tabbed Ring of the frame. Loosely secure the Wire using Wire Bolts during the placement of the Half Pin to allow for minor adjustments.

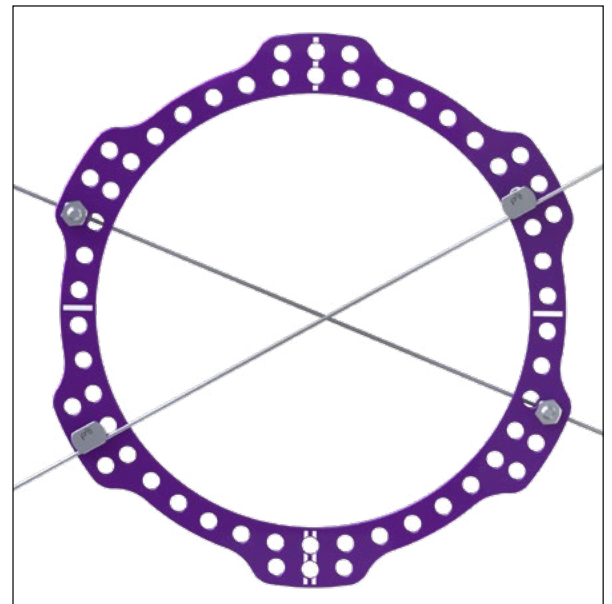

NOTE: If two Wires are used in a single ring, each Wire should alternate in placement to be above and below the ring.

CIRCULAR EXTERNAL FIXATION APPLICATION

Per surgeon preference, a second Half Pin may be placed at the second most proximal Tabbed Full Ring. Refer to page 15 for instruction on Half Pin placement.

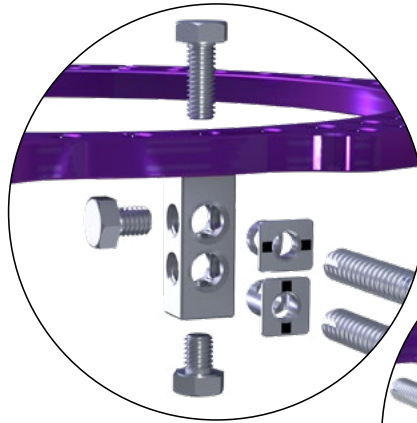

Rancho Cube assembly with Rancho Cube Centering Collars

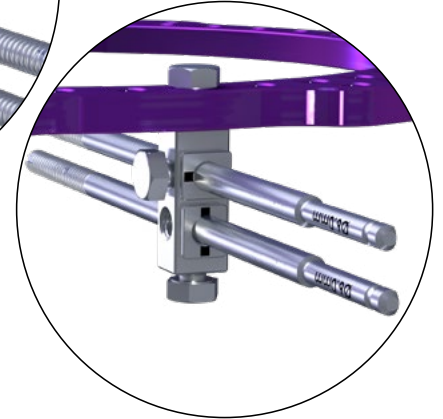

Half Pins used in the same plane are used in this image to show the function of the Rancho Cube, but only one Half Pin per plane is recommended.



NOTE: The laser etching of the Rancho Cube Centering Collar must be in the same orientation as the 8 mm Connecting Bolt to lock the Centering Collar in place.



OPTIONAL: The Monkey Rings™ system is designed to work with the The Monkey Bars™ Pin to Bar External Fixation System Clamps. The Threaded Pillars are 11 mm, in order to accommodate a combination clamp attachment. A Monkey Bar, 11 mm Bar, and 5 mm Pin Combination Clamp may be used to attach a 5 mm Half Pin directly to the Monkey Rings Threaded Pillar, as demonstrated here.



Any excess Wires may be removed using the provided Wire Cutters.



Any excess Half Pin may be removed using the provided Pin Cutters.



Per surgeon preference, a Pin Cap may be place over the cut end of the Half Pin.

CIRCULAR EXTERNAL FIXATION APPLICATION

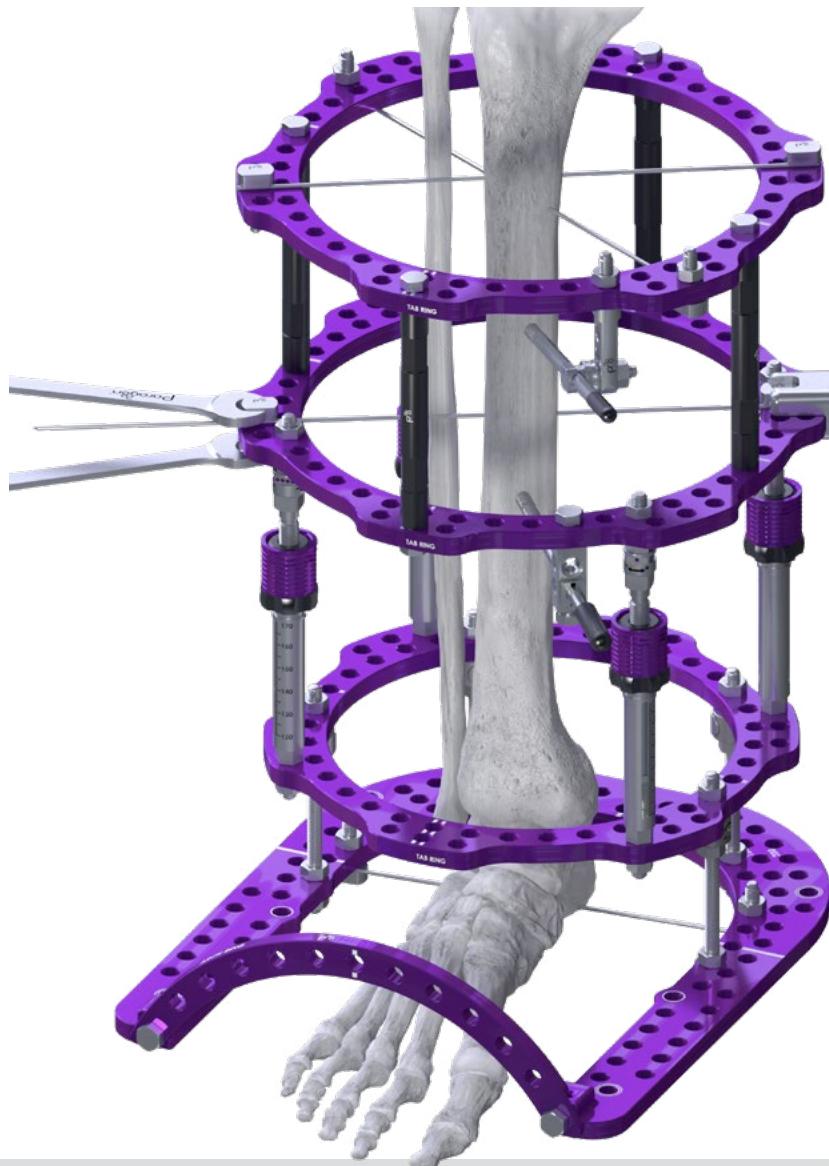

Fully tighten one Wire Bolt per Wire at this time using the provided Wrench. Tension the Wire until 125 kg of tension is reached.

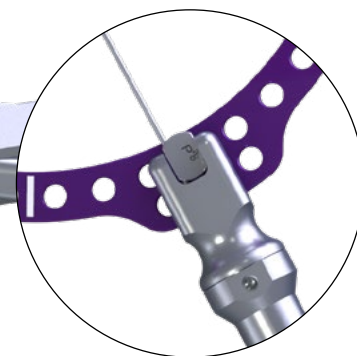

Wire Tensioner

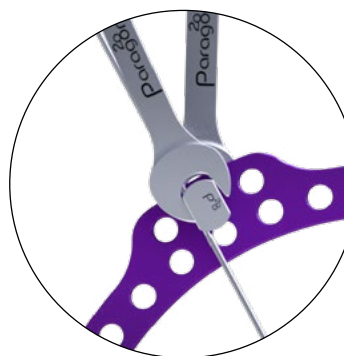

Wrench tighten

OPTIONAL:

If two Wires are used on the same ring, absent of any Half Pins placed, simultaneous tensioning should be performed to prevent deformation of the ring. An angle of 30° to 60° is recommended between each Wire to prevent the bone from translating after Wire fixation is placed. Placement of opposite side Reduction Wires, as shown in this image, will also help prevent translation in the bone and increase stability. If using Reduction Wires, make sure the olive portion of the Wires is apposed to the bone prior to tensioning.

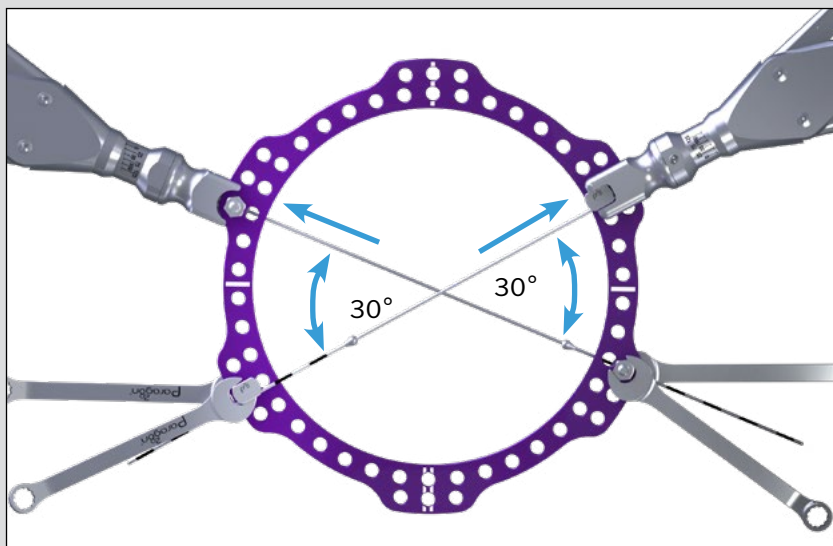

CIRCULAR EXTERNAL FIXATION APPLICATION

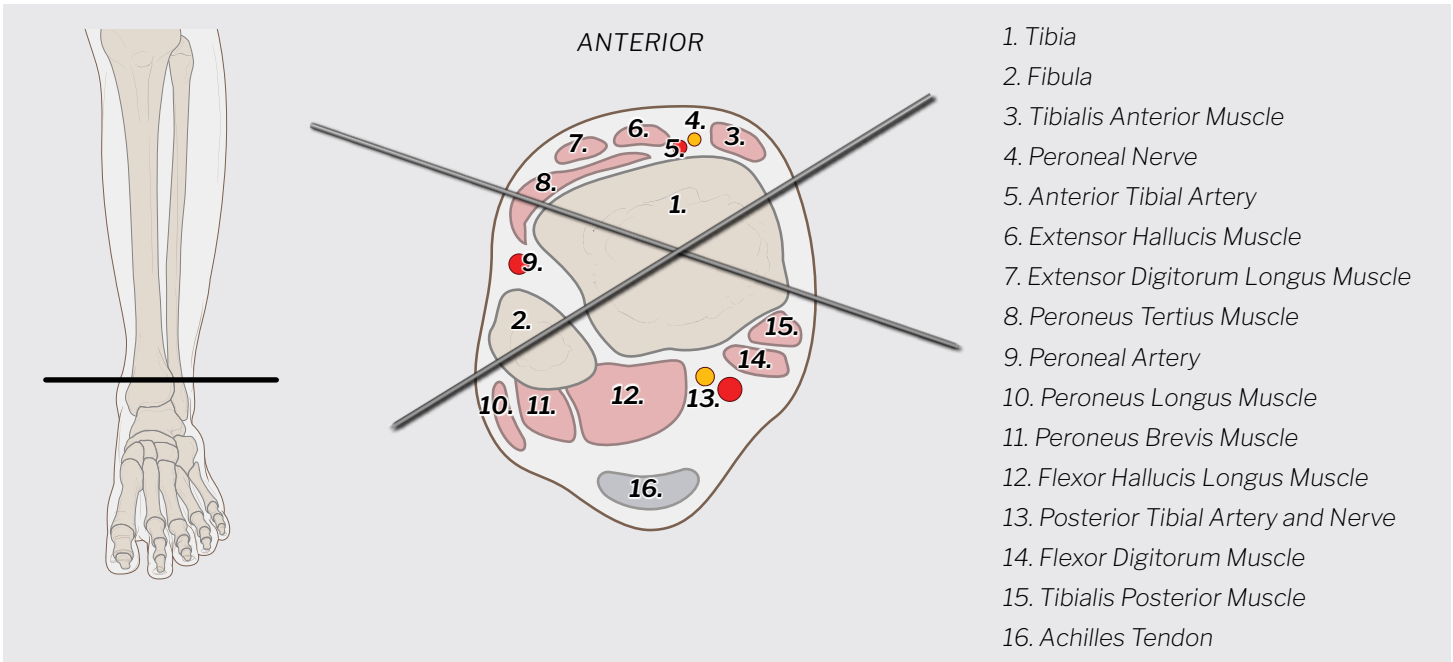

Care should be taken to avoid all major landmarks depicted above.

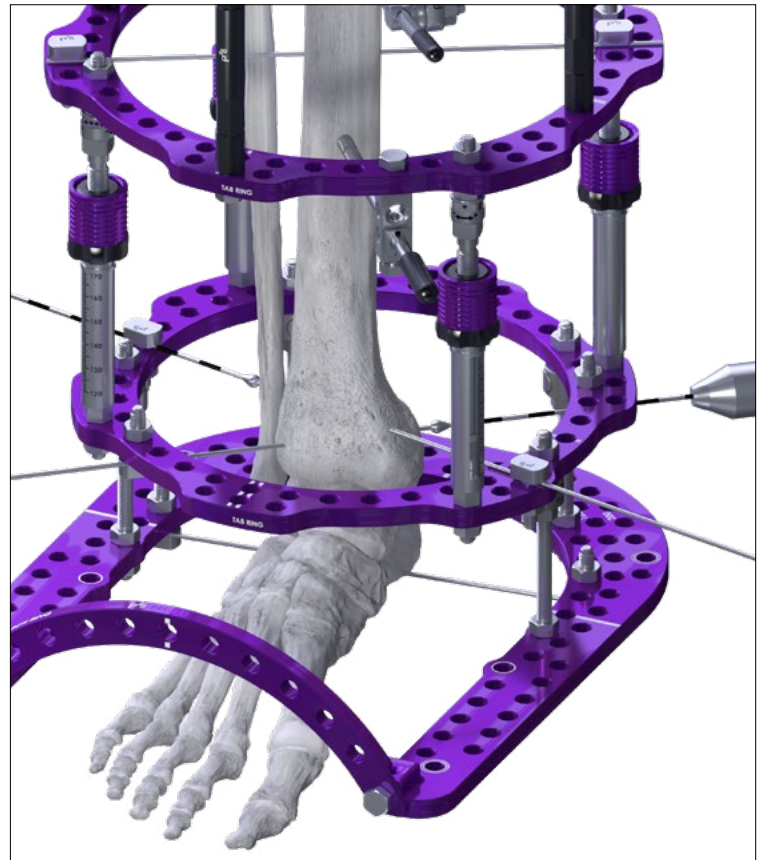
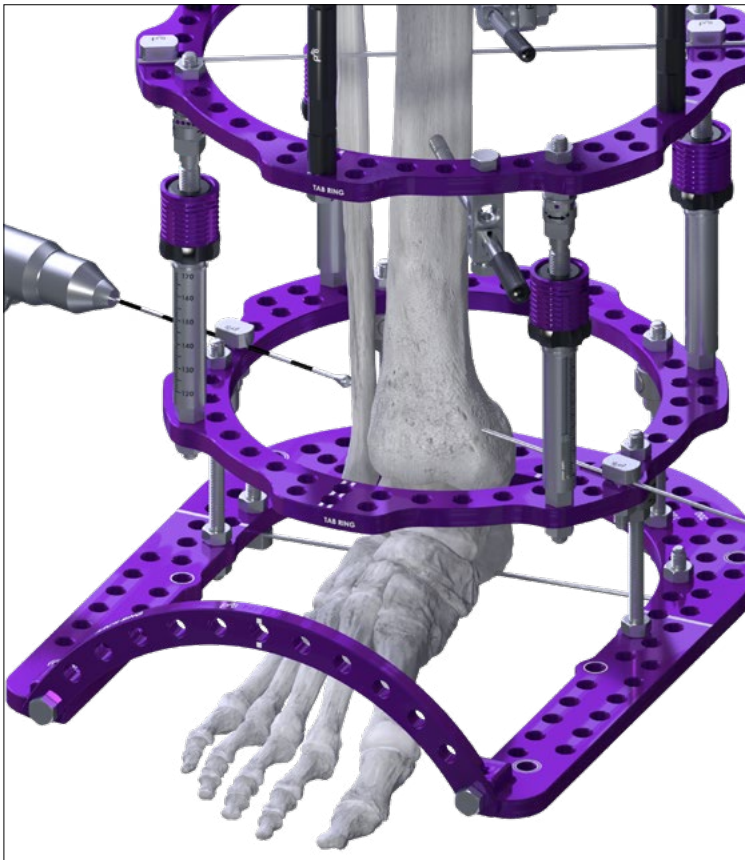

Similar to the proximal tibial ring block, each Reduction Wire should be placed in an alternating position above and below the Full Ring to avoid interference and deflection with the other Wire. Fully tighten one Wire Bolt per Wire, at this time using the provided Wrench.

CIRCULAR EXTERNAL FIXATION APPLICATION

Simultaneously tension the Reduction Wires from opposite ends until 125 kg of tension is reached.

NOTE: If using Reduction Wires, the Wire should be secured to the frame on the dashed side of the Wire. The Wire Tensioner should be placed on the non-dashed side.

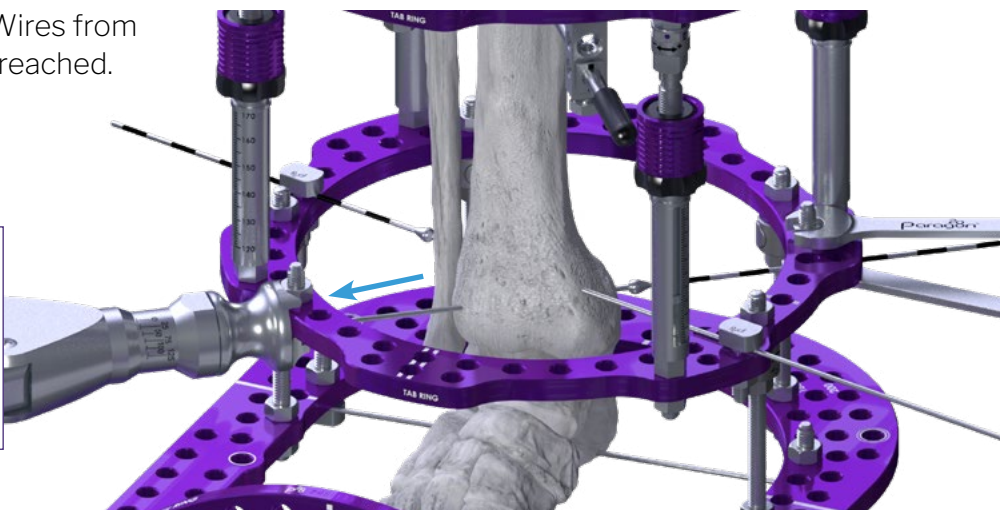

After desired tension has been achieved, fully secure the Reduction Wires to the Full Ring using the provided Wrench. The excess Wire may be bent or clipped per surgeon preference.

Distal tibial Wires are shown here to demonstrate adding stability to a static construct. Once distal tibial Wires are placed, compression may not be obtained using the Quick Adjust Struts any more in this scenario.

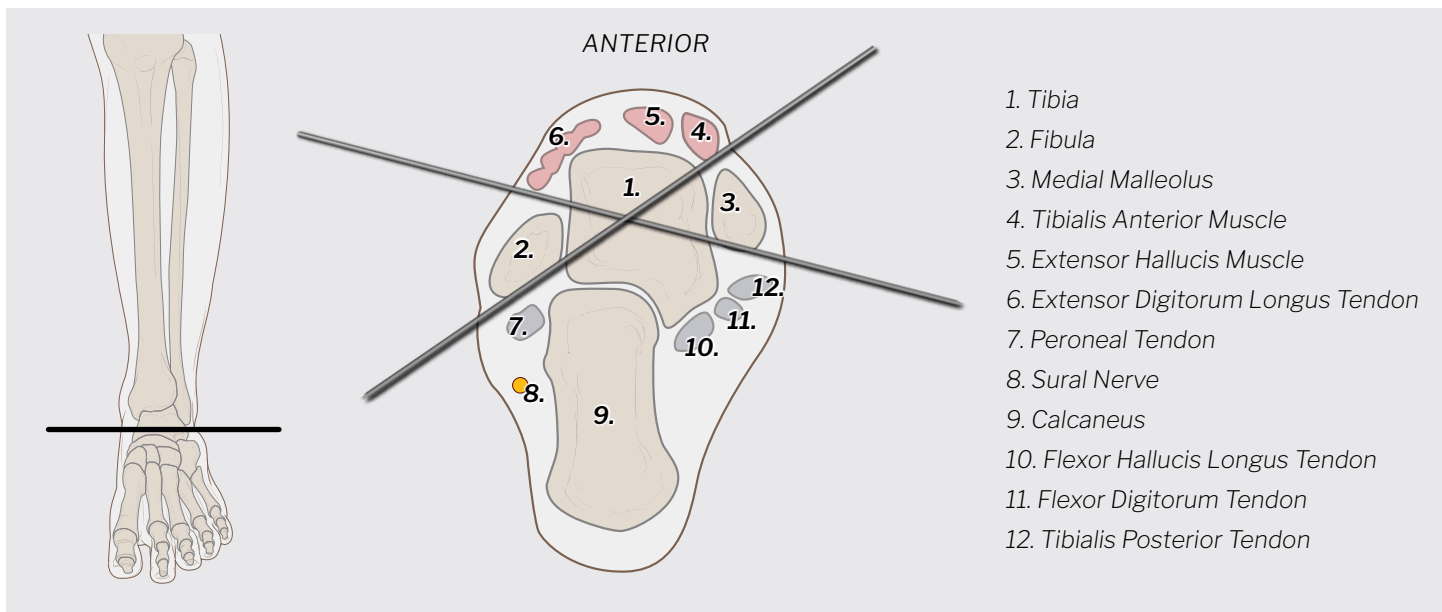
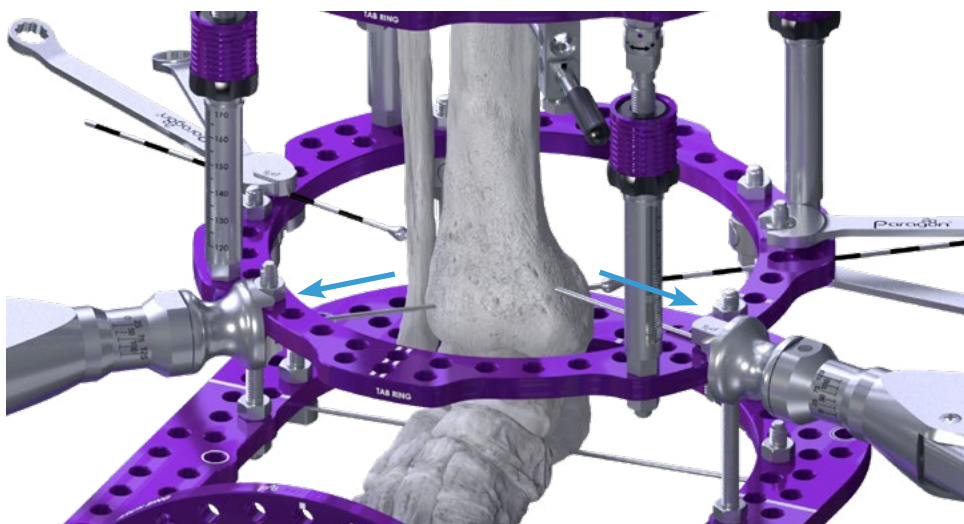

Care should be taken to avoid all major landmarks depicted above.

CIRCULAR EXTERNAL FIXATION APPLICATION

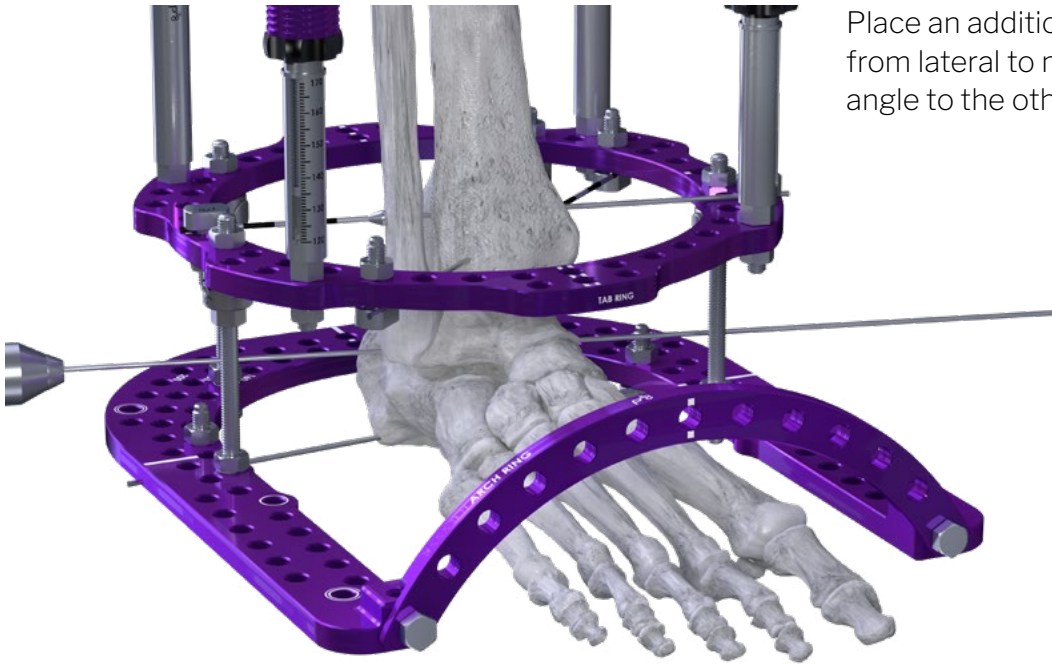

Place an additional Wire through the calcaneus from lateral to medial with a minimum of a 30° angle to the other Wire.

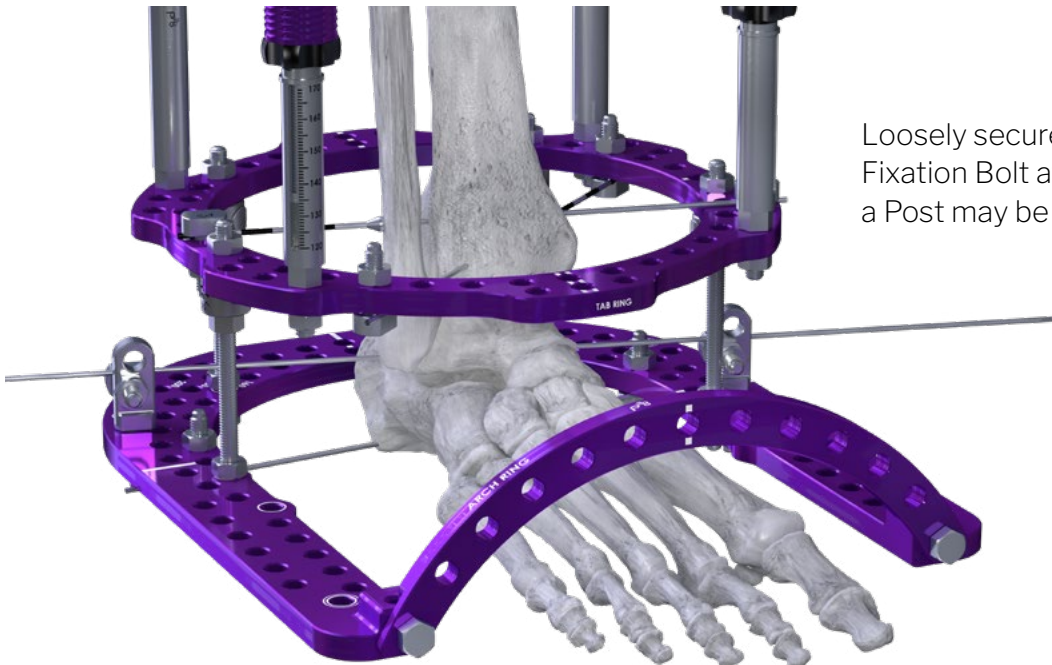

Loosely secure the calcaneal Wire with a Wire Fixation Bolt at this time. Per surgeon preference, a Post may be used to secure the Wires.

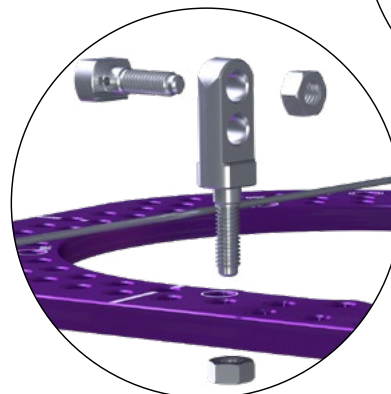

2-Hole Extension Post assembly to Wire Bolt on Foot Plate

CIRCULAR EXTERNAL FIXATION APPLICATION

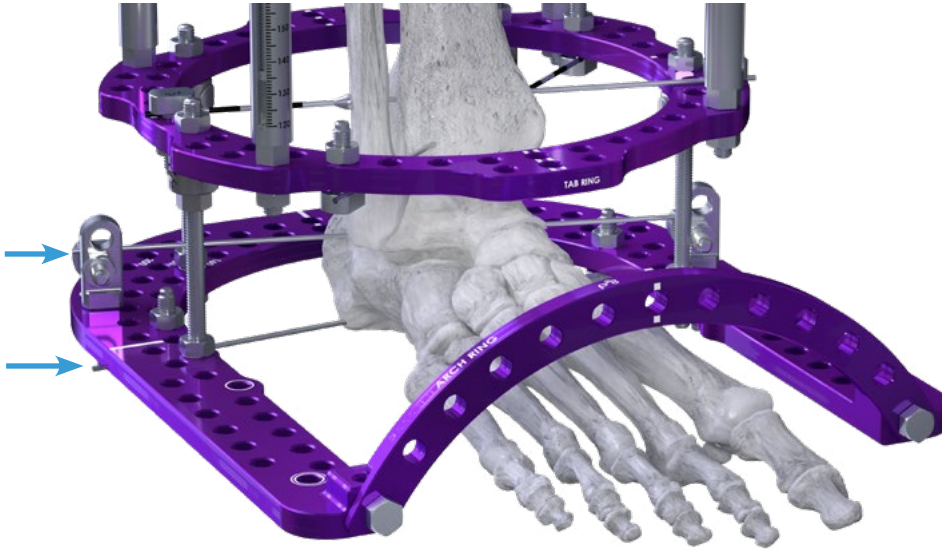

Both calcaneal Wires should alternate in placement above and below the Foot Plate to avoid skiving and interference with the other Wire. It is recommended not to tension the calcaneal Wires until the midfoot Wires have been tensioned.

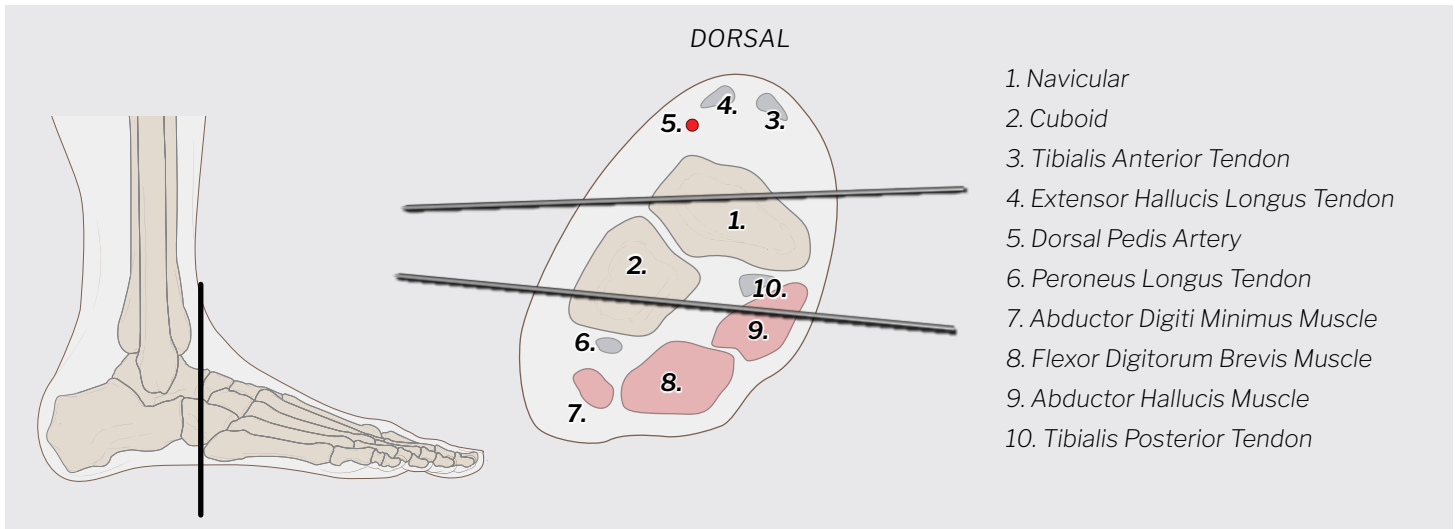

Care should be taken to avoid all major landmarks depicted above.

Place a Reduction Wire through the medial midfoot.



NOTE: The medial Reduction Wire should aim for the middle of the navicular. In the case of soft bone, a Washer may be used.

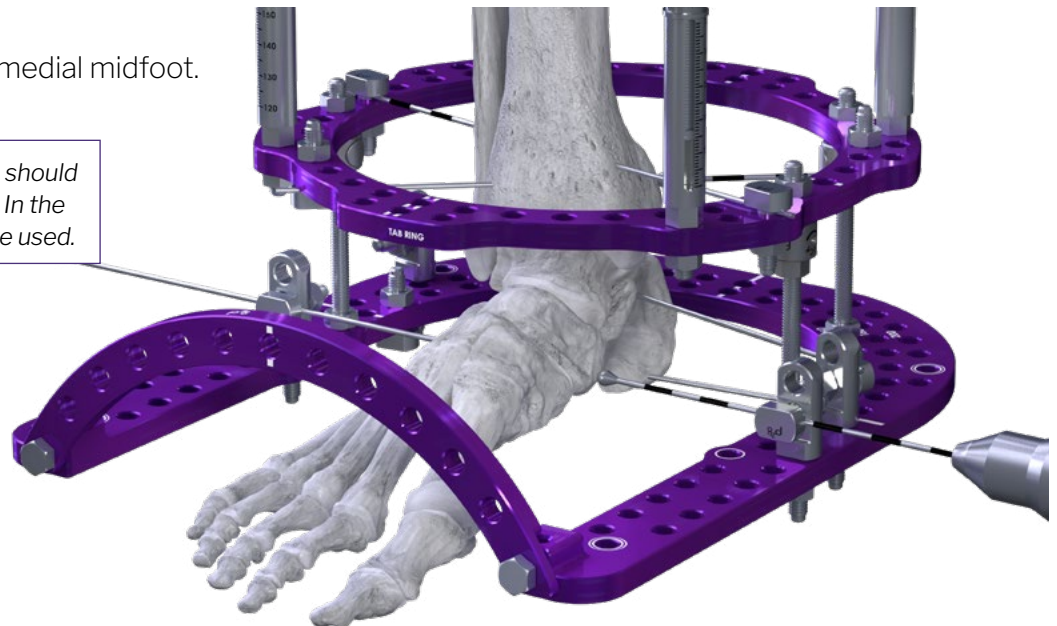

CIRCULAR EXTERNAL FIXATION APPLICATION

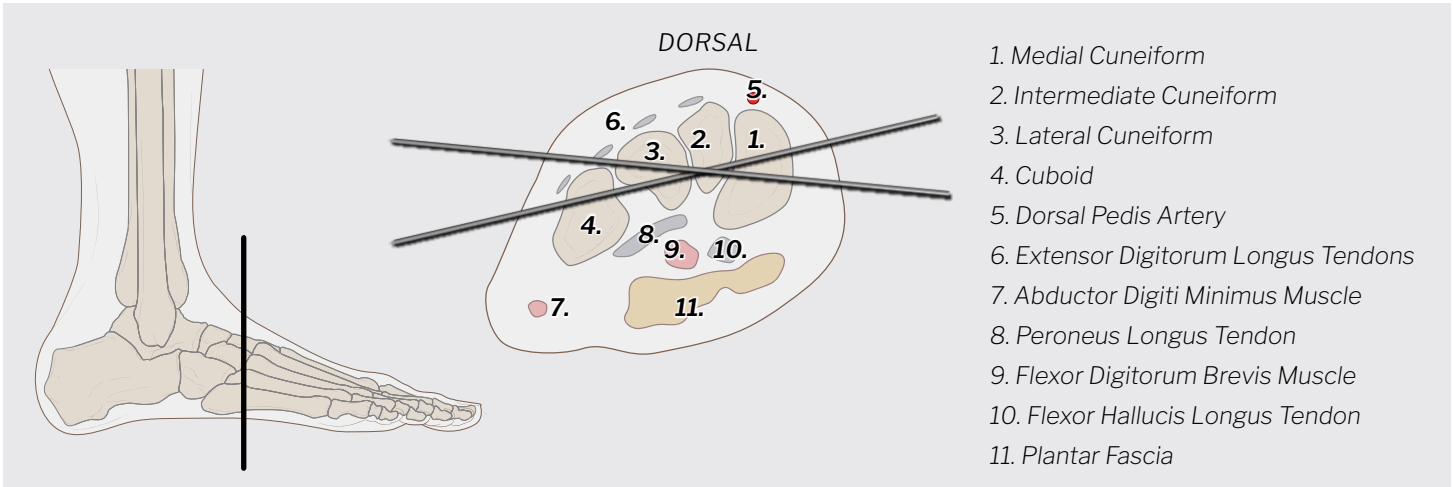

Care should be taken to avoid all major landmarks depicted above.

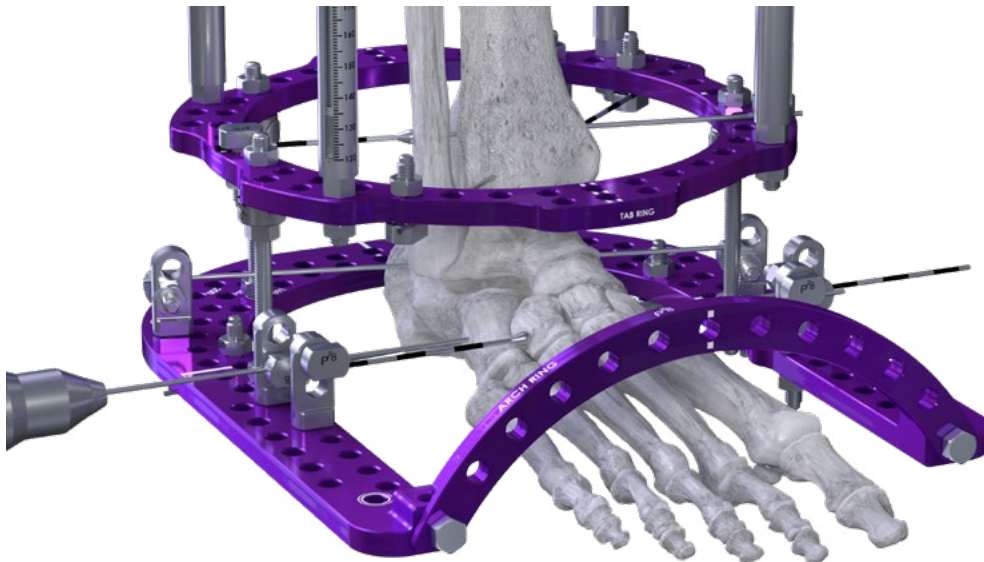

Place a second Reduction Wire though the lateral midfoot.

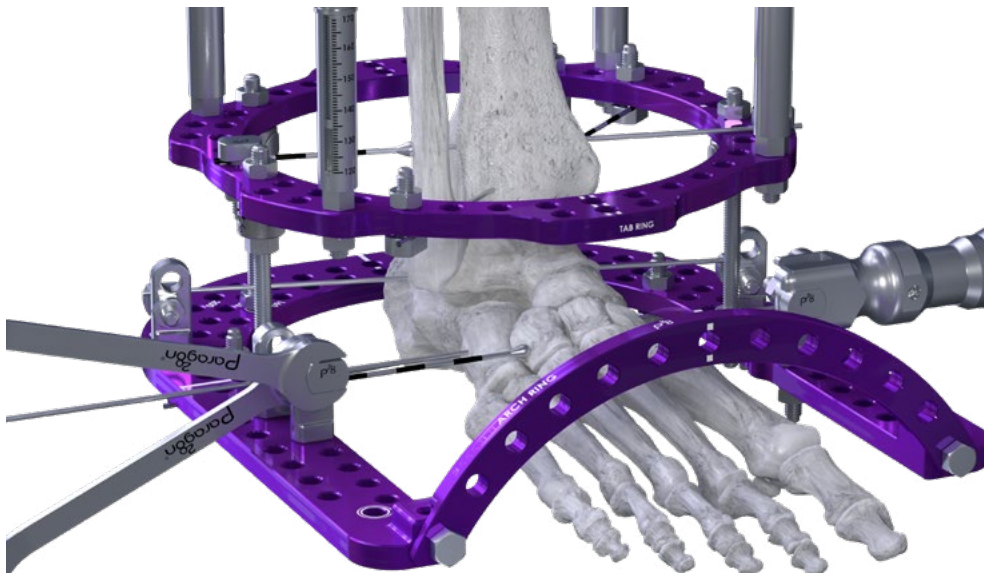

Simultaneously tension the two midfoot Wires to 80-100 kg. This should be completed before the tensioning of the calcaneal Wires.



NOTE: Forefoot Wires may be used in addition to the midfoot Wires per surgeon preference. In the instance that forefoot Wires are used, the Wires should be tensioned to 50-70 kg.

CIRCULAR EXTERNAL FIXATION APPLICATION

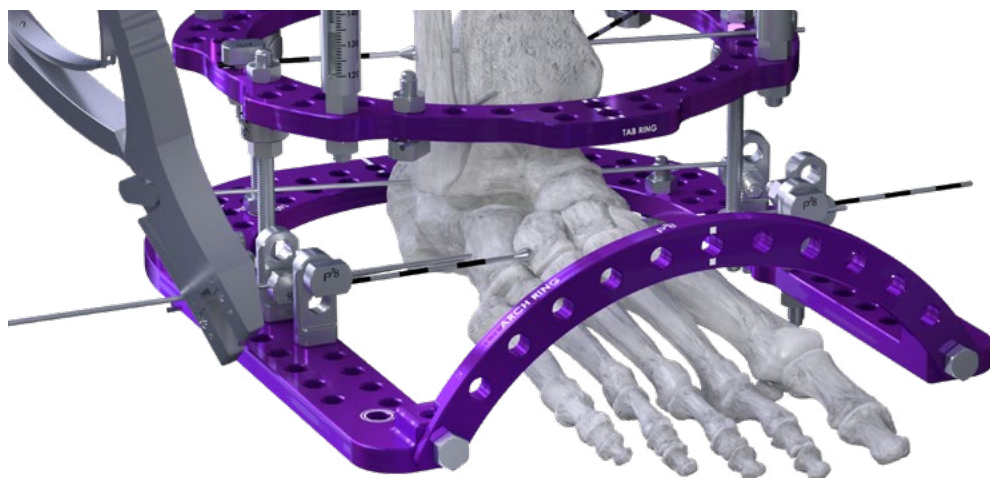

Excess Wire may be cut using the provided Wire Cutter at this time.

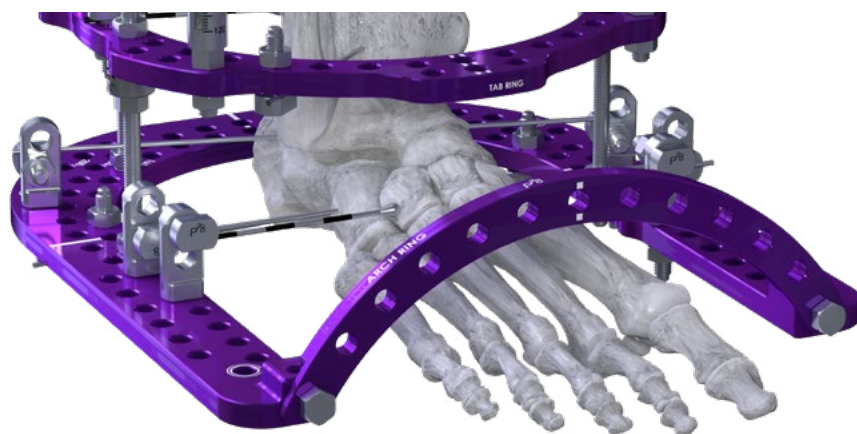

If not previously done, all Half Pins and Wires may be cut using the provided Pin Cutter/Wire Cutter.

Any additional supporting Threaded Rods or Threaded Pillars may be added per surgeon preference.

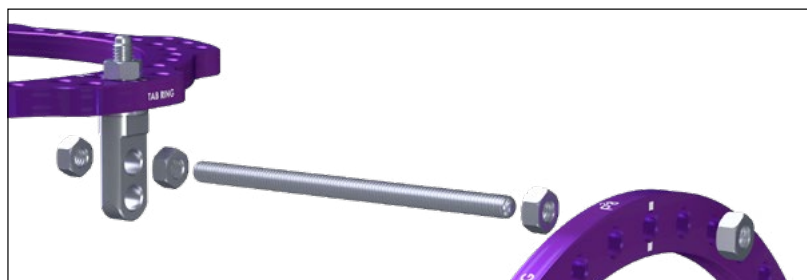

Threaded Rod assembly to Arch Ring and 2-Hole Extension Post

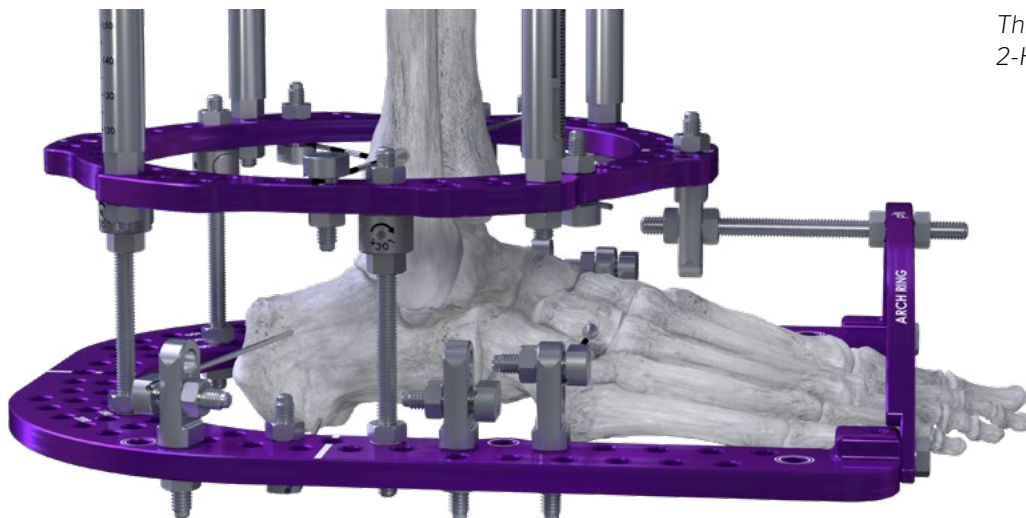

An additional Extension Post may be added to the anterior portion of the most distal ring to connect the Arch Ring using a Threaded Rod. Secure the Threaded Rod using 10 mm Nuts.

CIRCULAR EXTERNAL FIXATION APPLICATION

The Strut Locking Clip is recommended to prevent any tampering or gross adjustment of the Quick Adjustment Strut postoperatively.



Ø6.0 mm protective Pin Caps and Wire Clamp Caps should be placed over the cut Half Pins and Wires, respectively, to protect the soft tissue.

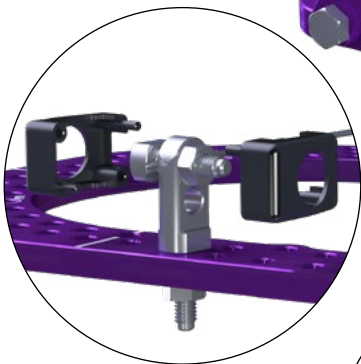

Wire Clamp Cap assembly

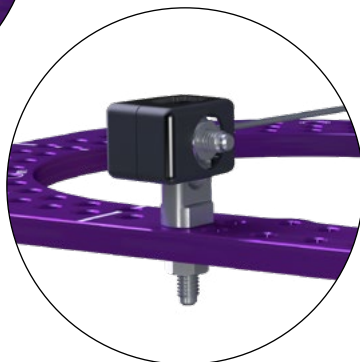

CIRCULAR EXTERNAL FIXATION APPLICATION



Anti-microbial Sponges are provided to be placed over Wires against the patient's skin to help prevent infection.



Per surgeon preference, a Foot Rocker Kit is provided to allow weight bearing. The Foot Rocker allows for anterior and posterior translation.

Attach the Foot Rocker to the Foot Plate through the plate holes with laser marked double ring. Use four 10 mm M6 Connecting Nuts and secure the Foot Rocker with the provided Wrench.

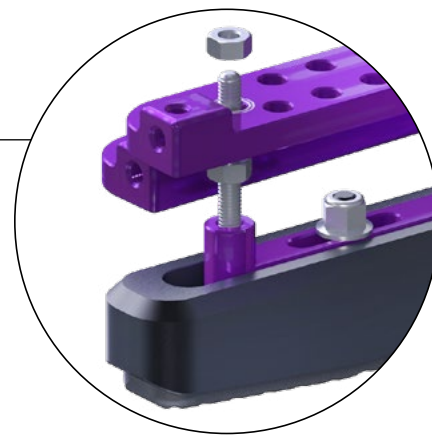

The Foot Plate has double rings to note the placement of the Foot Rocker.

CLOSURE

Proceed to incision closure or concomitant procedures at this time. Provide a final check that all Nuts (Including Quick Release Locking Nuts) and Bolts are tightened and secured.

REMOVAL

For the removal of the frame, use a Jacob's Chuck to remove the Half Pins and cut the Smooth/Reduction Wires with the provided Wire Cutter. After removal of all Wires and Half Pins, slide the frame off the patient.

Refer to www.paragon28.com/ifus for the complete and most current instructions for use document.

INDICATIONS FOR USE

The Monkey Rings™ External Fixation System is indicated in pediatric patients and adults for the treatment and fixation of:

- Open and closed fractures
- Post-traumatic joint contracture which has resulted in loss of range of motion
- Fractures and disease which generally may result in joint contractures or loss of range of motion and fractures requiring distraction
- Pseudoarthrosis, infected union, non-union, or malunion of long bones
- Limb lengthening by epiphyseal, diaphyseal, or metaphyseal distraction
- Correction of bony or soft tissue deformity (e.g. orthoplastic surgery)
- Correction of segmental bony or soft tissue defects
- Joint arthrodesis
- Management of comminuted intra-articular fractures
- Bone transport

The Monkey Rings™ External Fixation System is indicated in adults for:

- Osteotomy
- Revision procedure where other treatments or devices have been unsuccessful
- Bone reconstruction procedures
- Fusions and replantations of the foot
- Charcot foot reconstruction
- Offloading and/or immobilization of ulcers and/or wounds of the foot and ankle
- Lisfranc dislocations
- Ankle distraction (arthrodiastasis)
- Septic fusion

CONTRAINDICATIONS

Since external fixation devices are often used in emergency situations to treat patients with acute injuries, there are no absolute contraindications for use. The surgeon's education, training and professional judgment must be relied upon to choose the most appropriate device and treatment for each individual patient.

Whenever possible, the device chosen should be of a type indicated for the fracture being treated and/or for the procedure being utilized.

In addition, surgical success can be adversely affected by:

- Acute or chronic infections, local or systemic, and patients with a history of infection
- Vascular, muscular or neurological pathologies that compromise the concerned extremity
- All concomitant pathologies that could affect the function of the devices
- Osteopathies with reduced bone substance that could affect the function of the devices
- Any mental or neuromuscular disorder that could result in an unacceptable risk of failure at the time of fixation or complications in post-operative treatment. The risk of breakage of a fixation device is greater in older patients with mental deficiency, alcoholics or drug addicts or patients who, for other reasons, may ignore the necessary restrictions and precautions to be observed while using the device.
- Known or suspected sensitivity to device materials
- Corpulence; an overweight or corpulent patient can strain the implant to such a degree that stabilization or device failure can occur

POTENTIAL COMPLICATIONS AND ADVERSE REACTIONS

In any surgical procedure, the potential for complications and adverse reactions exist. The risks and complications with these implants include:

- Loosening, deformation, migration, subluxation, fracture of the device, or premature loss of fixation with the bone which may result in nerve and soft tissue damage
- Delayed union, non-union, or malunion resulting in breakage of the construct. If healing is delayed, or does not occur, the construct may eventually break due to the increased loading.
- Acute post-operative wound infections and late infections with possible sepsis and osteomyelitis, including chronic drainage of the Schanz screw sites following removal of the device.
- Migration, subluxation of the implant with resulting reduction in range of movement
- Thrombosis or embolism
- Avascular necrosis
- Tissue necrosis, wound hematoma and delayed wound healing
- Excessive surgical bleeding
- Temporary and protracted functional neurological perturbation
- Tissue reactions as the result of allergy or foreign body reaction to dislodged particles
- Corrosion with localized tissue reaction and pain
- Pain, a feeling of malaise or abnormal sensations due to the implant used
- Bone loss due to stress shielding

Refer to www.paragon28.com/ifus for the complete and most current instructions for use document.

- Shortening of the affected bone/fracture site.
- Bone loss or reduced bone density due to a reduction in the tension applied to the bone.
- Fractures resulting from unilateral joint loading
- Edema or possible compartmental syndrome.
- Premature bone callus consolidation during distraction.
- Possible tension affecting the soft tissues and/or the fixation during manipulation of the callus (e.g. corrections of deformities and/or elongation).
- Fracture of regenerated bone, or at the Schanze screw holes, following removal of the device.
- Bone damage due to erroneous Schanze screw selection.
- Bone deformities or talipes equinus.
- The persistence or recurrence of the initial condition subject to treatment.
- Abnormal growth cartilage development in skeletally immature patients.
- Pressure on the skin caused by external components when the free space is insufficient.
- Secondary bony sequestration due to rapid perforation of the cortex with accumulation of heat and bone necrosis.
- Nerve or vascular damage following the insertion of Schanze screws or wires.
- Do not use other manufacturer's instruments or implants in conjunction with the Monkey Rings™ External Fixation System.

MR SAFETY INFORMATION

The Monkey Rings™ External Fixation System has not been evaluated for safety and compatibility in the MR environment. It has not been tested for heating, migration, or image artifact in the MR environment. The safety of the Monkey Rings™ External Fixation System in the MR environment is unknown. MR scanning of a patient who has this device may result in patient injury.

All possible complications listed here are not typical of Paragon 28® Inc. products but are in principle observed with any implant. Promptly inform Paragon 28® in the event that complications occur in connection with the implants or surgical instruments used. In the event of premature failure of an implant in which a causal relationship with its geometry, surface quality or mechanical stability is suspected, please provide Paragon 28® with the explant(s) in a cleaned, disinfected and sterile condition. Paragon 28® cannot accept any other returns of used implants. The surgeon is held liable for complications associated with inadequate asepsis, inadequate preparation of the osseous implant bed in the case of implants, incorrect indication or surgical technique or incorrect patient information and consequent non-compliant patient behavior.

WARNINGS AND PRECAUTIONS

- The patient must be informed that a second minor surgery for the removal of the fixation system is required.
- Re-operation to remove or replace implants may be required at any time due to medical reasons or device failure. If corrective action is not taken, complications may occur.
- The implants and guide wires are intended for single use only.
- Guide wires and Schanze screws are to be treated as sharps.
- Do not reuse single use devices. Reuse of single-use external fixators may lead to reduced biomechanical properties and/or fatigue breakage of the devices.



MONKEY RINGS

PATENTED, DESIGNED & EXCLUSIVELY DISTRIBUTED BY

Exclusively foot & ankle **28**
Paragon[®]

P45-STG-0001 RevB [2022-05-31]

™Trademarks and ®Registered Marks of Paragon 28®, Inc.
© Copyright 2022 Paragon 28®, Inc. All rights reserved.
Patents: www.paragon28.com/patents

Paragon 28®, Inc. 
14445 Grasslands Dr.
Englewood CO, 80112 USA
(855) 786-2828
www.paragon28.com

DISCLAIMER

The purpose of the Monkey Rings™ Circular External Fixation System Surgical Technique Guide is to demonstrate the optionality and functionality of the Monkey Rings™ Circular External Fixation System implants and instrumentation. Although variations in placement and use of the Monkey Rings™ Circular External Fixation System implants can be performed, the fixation options demonstrated in this technique were chosen to demonstrate the functionality of the system and for simplicity of explanation. Other uses for the Monkey Rings™ Circular External Fixation System can be employed, appropriate for the size of the device. CAUTION: Federal Law (USA) restricts this device to sale and use by, or on the order of, a physician.